



HERMetic Valves for gauging and sampling

HERMetic Compact valves are specially designed to support all portable HERMetic equipment with HERMetic quick connector and represent the base for the zero-ullage reference when installed at the appropriate height. They ensure a safe and reliable operation of all portable HERMetic units certified for use in classified areas. They are available in three different size 1 inch, 2 inch and 4 inch.

Vapour lock valves

HERMetic Compact Valves for connection of portable HERMetic equipment, specially approved & certified for marine application.

The **HERMetic Compact valves** are specially designed to fit all portable HERMetic equipment with a HERMetic quick connector and represent the base for the zero-ullage reference when installed at the appropriate height. They ensure a safe and reliable operation of all portable HERMetic units certified for use in classified areas. The valves are available in three different sizes: 1 inch, 2 inch and 4 inch. HERMetic valves are approved by all major classification societies.

HERMetic Compact valves C1-SS-W

1inch full bore ball valve with 1inch male BSP pipethread designed to support all portable HERMetic equipment with HERMetic 1inch quick connector.

Weight: 1 kg

HERMetic Compact valves C1-SS-P

1inch valve fitted with a special pressure cap cover. This cover is specially designed for use with hazardous chemicals and protect against inadvertent opening.

Weight: 1.2 kg

Materials: Stainless Steel AISI 316, PTFE seats

HERMetic Compact valves C2-SS-BL

2 inch full bore ball valve made of corrosion resistant stainless steel with high Molybdenum content. The top part is designed to support HERMetic equipment with 2 inch quick connector.

*Option: Special handle for pad lock.

Weight with DUJ flange: 4,8 kg

Weight with female thread: 4 kg

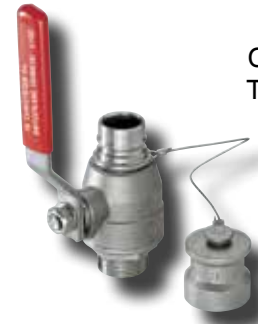

C1-SS-W
TS 10055



C1-SS-P
TS 10080



C2-SS-BL
TS 10081

C2-SS-BL Female
TS 10085

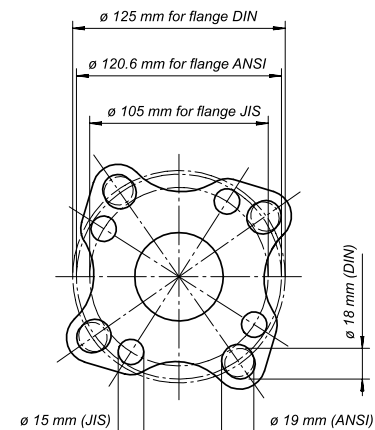

All HERMetic 2 inch ball valve are available with 2 inch female thread or with DUJ multistandard flange.

DUJ multistandard flange fits following standards:

- DIN PN 10 DN 50
- DIN PN 16 DN 50
- DIN PN 25 DN 50
- DIN PN 40 DN 50
- JIS 5K 50
- JIS 10K 50
- ANSI 150 lbs 2 inch

Materials:

Stainless steel AISI 316 with minimal Mo content 2.7%, PTFE seats

Vapour lock valves

HERMetic Compact valves C2-SS-W

Same valve as HERMetic Compact valve C2-SS-BL except the cover, which is fitted with a 1 inch quick-connect nipple identical to the one supplied on the smaller C1-SS-W Compact valve. This nipple matches with all HERMetic units and accessories with 1 inch connection. The complete cover can be removed for connection of equipment with 2 inch connector.

*Option: Special handle for pad lock.

Weight: 5,1 kg

Materials: Stainless steel AISI 316, PTFE seats



C2-SS-W
TS 10083



C2-SS-W Female
TS 10076

HERMetic Compact valves C2-SS-SEC

Same valve as HERMetic Compact valve C2-SS-BL except a doubly locked security cover which prevents any water ingress and protects against inadvertent opening. The cover is secured to the valve with a stainless steel cable. Specially designed for hazardous chemicals.

*Option: Special handle for pad lock.

Weight: 5,4 kg

Materials: Stainless steel AISI 316, PTFE seats

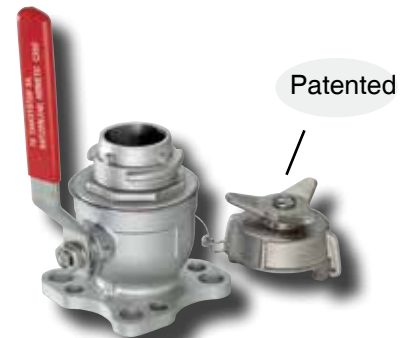

Patented

C2-SS-SEC
TS 10082



C2-SS-SEC Female
TS 10078



HERMetric Deck Valve A-4 SS

Specially designed heavy-duty compact ball valve totally made of stainless steel 316 and with FKM gaskets. The deck flange is according to ANSI 150 lbs. standard. This 4 inch deck valve is provided with a swing away cover fitted with a 1 inch quick-connect male coupling. This coupling takes all HERMetric equipment fitted with a 1 inch female quick connector. For sampling, open the cover and install the HERMetric Sampler A-4 or Sampler GT4 on top of the valve. Three wing nuts are used to secure the cover or alternatively the sampler chamber.

Weight: 24 kg

Materials: Stainless steel AISI 316, PTFE seats



HERMetric Deck Valve A-4-2-1 SS

This valve has been specifically designed so that all the HERMetric equipment, with either 1inch, 2inch, or 4inch connections, will be compatible. Organisations such as the American Petroleum Institute and the Energy Institute, recommend the size of the vapour valve to be 4inch (100 mm). The 4inch valve will allow access to a larger number of gauging and sampling equipment than ever before, depending on the product and sample type required. Vapour valves smaller than 100 mm in diameter are suitable for gauging but can severely limit the type of sampling equipment that can be used and, ultimately, the quality of the sample. The size and location of the vapour valve for closed system measurement and sampling is critical to the process. A valve of the proper size, located correctly, will allow more accurate measurements to be taken than one that is improperly located and of insufficient size. The new multi-purpose valve gives the flexibility to gauge products from crude to chemicals. Most importantly, it will allow the use of sampling equipment with the capabilities of retrieving sample quantities from 0.33 litres to 1.8 litres in one single operation.

Weight: 25 kg

Materials: Stainless steel AISI 316, PTFE seats



Honeywell

Enraf Tankssystem SA

Rue de l'Industrie 2

1630 Bulle, Switzerland

Tel: +41 (0) 26 919 15 00

Fax: +41 (0) 26 919 15 05

E-mail: tankssystem@honeywell.com

www.tankssystem.com

HM-13-13-ENG

February 2013

© 2013 Honeywell International Inc.

Honeywell