

CUP-BB3

HEAVY DUTY, AXIALLY SPLIT,
MULTI-STAGE PUMPS

CLYDEUNION®
PUMP



CLYDEUNION PUMPS - AN INTRODUCTION

ClydeUnion Pumps is the culmination of a long and eventful 140-year engineering legacy. In fact, most nuclear power plants currently in operation around the world employ our reactor feed pumps. We play an instrumental role in securing the vital energy and water resources that a sustainable society will rely on in the future.

Not only servicing the Nuclear market we are also a valued flow control engineering partner to the oil/gas industry - supporting upstream, downstream, transportation and offshore exploration activities. Other key areas we address include seawater desalination, waste water treatment, mining and steel production.

Combining a wealth of pump and system design knowledge, latest design, analytical and pump testing equipment, we are confident we can boost efficiency and ensure prolonged operation of our products.

HIGH TECHNOLOGY PUMPS FOR THE MOST DEMANDING SERVICES

At Celeros FT, you will find a commitment to quality throughout the company. Our Quality Management System is fully approved to ISO 9001:2008 and independently verified to comply with the latest quality standards. Our ClydeUnion Pumps brand has a worldwide reputation for providing optimised reliability, with our API 610 centrifugal pumps and pumping packages, in the most severe duty applications.

PIPELINES

The process and transferring of crude and refined products, often in remote locations, demands a high level of pumping reliability.

The ClydeUnion Pumps brand has a reputation for supplying reliable pumps which can be found working throughout the world in the most hostile environments.

OIL & GAS PRODUCTION

Our pumps can be found operating wherever there are oilfields, both onshore and offshore. High efficiency and reliability are major benefits of ClydeUnion Pumps equipment - both of which are vital considerations in the oil and gas industry. Pumps have been supplied to satisfy a wide range of pumping services including high pressure seawater injection, crude oil transfer and pumps for handling all types of industry related fluids.

Today's complex refinery processes demand specialised pumping solutions. Extremes of temperature, high pressure and the ability to handle volatile fluids, calls for highly engineered pumps that can perform reliably in such arduous conditions. With many years of worldwide experience in supplying ClydeUnion process pumps to the refinery industry we are committed to providing our customers with solutions for the most complex of pumping requirements.

TYPICAL APPLICATIONS

- Crude oil & product pipeline
- Seawater injection
- Refining charge
- Desalination - high pressure reverse osmosis (HPRO)
- Boiler feed
- Produced water injection
- Metals - high pressure descale

REVERSE OSMOSIS

With high efficiency and reliability, our multi-stage pumps are ideally suited for seawater reverse osmosis. The ClydeUnion Pumps CUP-BB3, combined with energy recovery systems, provides a very efficient solution for your high pressure reverse osmosis pumping needs.

POWER

ClydeUnion boiler feed pumps and auxiliary services have been supplied for a wide range of power generation plants over many years.



CUP-BB3 - HEAVY DUTY, AXIALLY SPLIT, MULTI-STAGE PUMPS

The ClydeUnion Pumps CUP-BB3 is a heavy duty, axially split, multi-stage, double volute horizontal pump with opposed impellers of either single or double suction first stage impeller options, designed for high pressure and high speed service. All units comply with the latest edition of API 610 and API 682 standards and are specifically designed for heavy duty, medium and high pressure applications.

The ClydeUnion Pumps CUP-BB3 flexibility of design allows the pump to be equally acceptable over a wide range of duties varying from standard water, oil and chemical applications to advanced water flood and boiler feed applications.

There are thousands of ClydeUnion Pumps CUP-BB3 pumps operating worldwide on services as diverse as:

- Seawater injection at 295 Bar (4,280 psi) discharge pressure and 6,200 rpm
- Pipeline applications
- Light hydrocarbon refinery services with a specific gravity of 0.45
- Sand laden crude oil where the CUP-BB3 running at 4 pole speeds has been used to replace traditional screw pumps

PROVEN PRODUCT INTEGRITY

The ClydeUnion Pumps CUP-BB3 encompasses a proven design history. The David Brown DB34, DB Guinard Pump DVMX, Union Pump Class M and the Mather & Platt FH all have an enviable history of

sound engineering, designed to exceed the rigorous requirements of API 610. API 610, providing the industry with a comprehensive hydraulic coverage.

EASE OF MAINTENANCE

The simple construction of the CUP-BB3 pump offers ease of maintenance and reliability. A complete rotor changeout can be completed in under eight hours. On arduous seawater injection services the CUP-BB3 pump is only opened every four years for internal inspection and overhaul. The CUP-BB3 enjoys enhanced efficiency which is achieved through additional polishing in high velocity areas of casing and the use of composite wear rings.

Overall, the pump offers minimum through life costs along with maximum reliability in service.

PUMPSETS + PACKAGES

ClydeUnion Pumps has extensive experience in providing complex pumpsets including electric motors, gearboxes, lube oil systems, steam turbines, diesel engines, control panels and instrumentation.

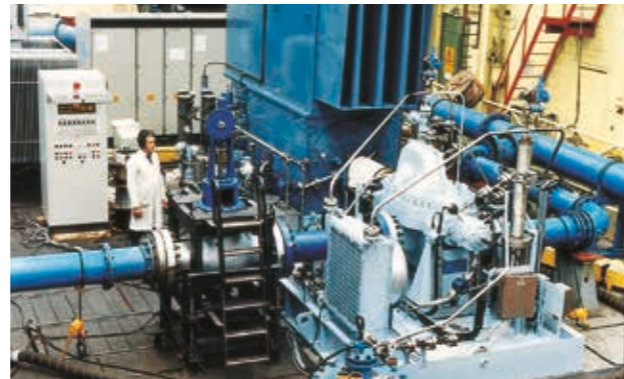

CUP-BB3-FEATURES

- 1 BEARING ASSEMBLY**
 - 360° mounting gives class leading vibration levels
 - High capacity fan as standard
 - Flinger design improves lubrication and prevents 'black oil'
 - Pure or purge mist options
- 2 SEAL CHAMBER**
 - API 682 compliant
 - Space for dual seals
 - Easy access for maintenance
 - Locking collar arrangement as standard
- 3 OPTIMUM NPSH PERFORMANCE**
 - Option for double suction impeller
- 4 CASE WEAR RINGS + BUSHES**
 - Positive location
 - Pinned for anti-rotation at split line
- 5 INTEGRALLY FLANGED AUXILIARY CONNECTIONS**
 - Eliminates weld connection
 - Eliminates need for bracing
 - Conventional options available
- 6 TOP BOLTED CAP NUTS**
 - Easy access and removal
- 7 DOUBLE VOLUTE DESIGN**
 - Minimises radial thrust loads for optimised bearing and seal life
- 8 SINGLE PIECE THROTTLE BUSHING**
 - Designed for pressure breakdown
 - Sized to balance axial thrust
- 9 HEAVY DUTY LUGS**
 - Rated for full pump weight
- 10 ROBUST ROTOR DESIGN**
 - Stepped shaft for ease of assembly
 - Optimised rotor dynamics and power transmission capability
- 11 INTEGRAL WEAR RINGS**
 - Reduced risk of failure due to wear part displacement
 - Retrofit with conventional rings when necessary
 - Conventional options available
- 12 FLANGE FINISHES + RATING**
 - Heavy duty class 900 as standard
 - Higher pressure options available
 - Raised face and ring type joint options available
- 13 NOZZLES INTEGRAL IN BOTTOM HALF CASE**
 - No need to remove pipework
 - Handles API 610 nozzle loads

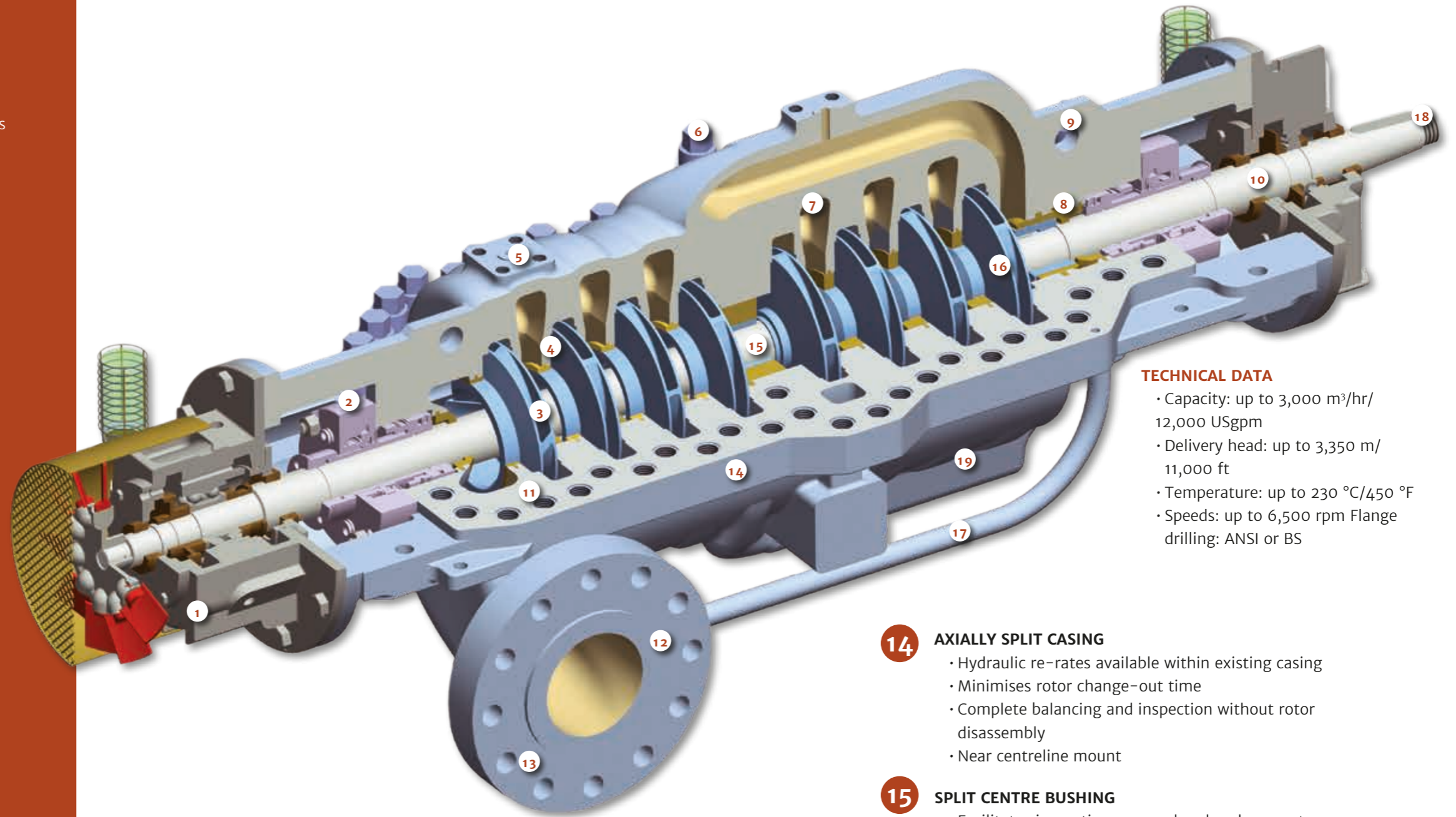

TECHNICAL DATA

- Capacity: up to 3,000 m³/hr/
12,000 USgpm
- Delivery head: up to 3,350 m/
11,000 ft
- Temperature: up to 230 °C/450 °F
- Speeds: up to 6,500 rpm Flange
drilling: ANSI or BS

- 14 AXIALLY SPLIT CASING**
 - Hydraulic re-rates available within existing casing
 - Minimises rotor change-out time
 - Complete balancing and inspection without rotor disassembly
 - Near centreline mount
- 15 SPLIT CENTRE BUSHING**
 - Facilitates inspection, removal and replacement
 - Maximises rotor support and dampening
- 16 IMPELLERS**
 - Back-to-back design to minimise axial thrust
 - Individually secured
 - Precision cast
- 17 INTEGRAL BALANCE LINE**
 - Equalises pressure in seal cavities
- 18 API SHAFT TAPER**
 - For easy coupling removal
- 19 MATERIAL OPTIONS**
 - All API 610 material options
 - Other material options available
 - NACE compatible
 - Non-metallic wear parts



ARRANGEMENTS & FEATURES

STANDARD BALL/BALL BEARING ASSEMBLY

- Designed for minimum 40,000 hour L10 life
- Surpasses the API limits for oil sump temperature and bearing temperature rise
- Angular contact bearings with machined brass cages
- Rapid bearing stabilisation achieves operating temperatures well within API limits
- INPRO™ bearing isolators throughout, give reduced contamination for improved bearing life
- Proven reliability in a wide range of applications, speeds and environments

OPTIONAL SLEEVE/BALL BEARING ASSEMBLY

- Energy density applications beyond ball/ball bearing limits
- Available for applications up to and beyond API limits
- Hydrodynamic radial bearing and optimally sized angular contact thrust bearings designed for 100,000 hour L10 life, under stable operating conditions
- Proven reliability on unattended pipeline pumping stations

OPTIONAL SLEEVE/TILTING PAD BEARING ASSEMBLY

- High power pumps up to 6.75 MW
- Designed for infinite life
- Standard designs are capable of withstanding transient process conditions

- Optimised designs available to withstand extreme transients in high energy applications
- Proven reliability in the most demanding service conditions

CP SEAL SYSTEM

- All CUP-BB3 pumps are designed for use with our patented CP System (Plan 53C)
- CP System technology offers a proven history in improving seal life, particularly under varying suction pressures
- The unique CP System design provides an excellent mechanical sealing environment in the most demanding process conditions

CARTRIDGE BEARING DESIGN

- “Maintenance friendly” design alternative, requiring a concession when used on an API pump
- Allows bearing removal and refit within an hour
- Cartridge can be pre-assembled in clean environment prior to transportation to the site
- Contains all the advanced features of our standard design

SPLIT WEAR RINGS

- Available for ease of maintenance

NON METALLIC WEAR PARTS

- Improved operation and performance efficiencies

INTER-STAGE TAKE-OFF

- Secondary fluid take-off line available for intermediate pressure and process flow requirements

STANDARD HYDRAULIC RANGE – COVERAGE CHARTS

50HZ RANGE COVERAGE CHART

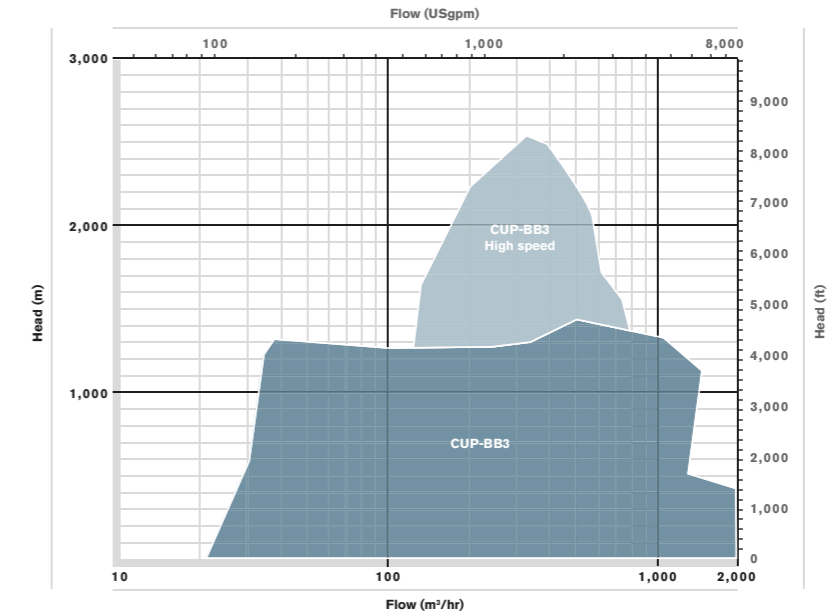

60HZ RANGE COVERAGE CHART

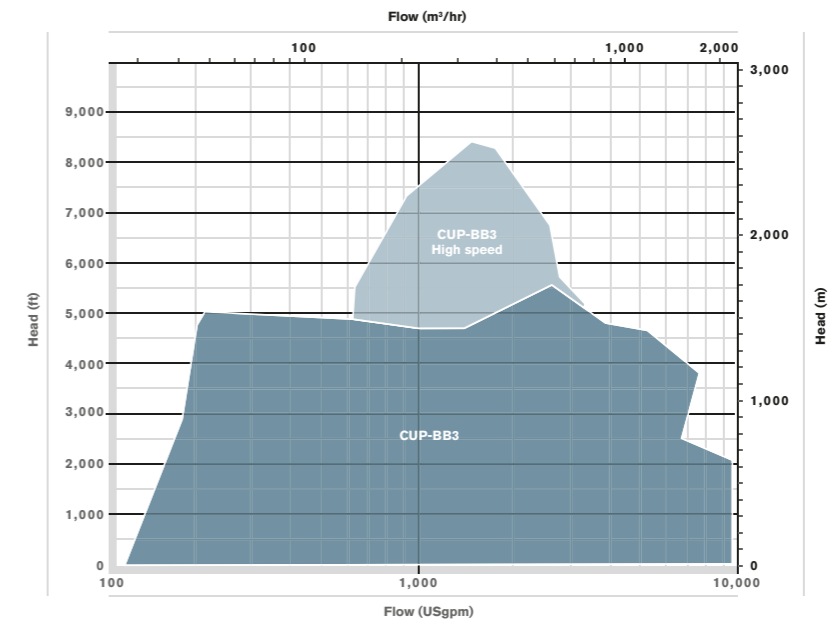

These charts cover the CUP-BB3 standard pump range.

Other engineering designs exist for extreme applications

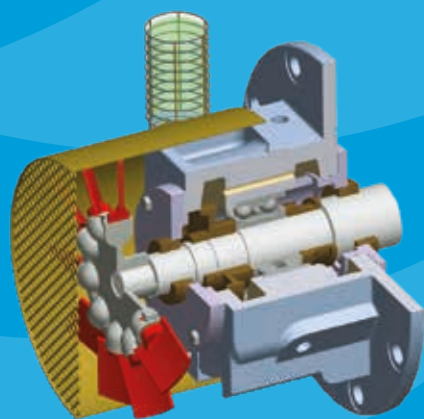

Standard ball /ball bearing assembly

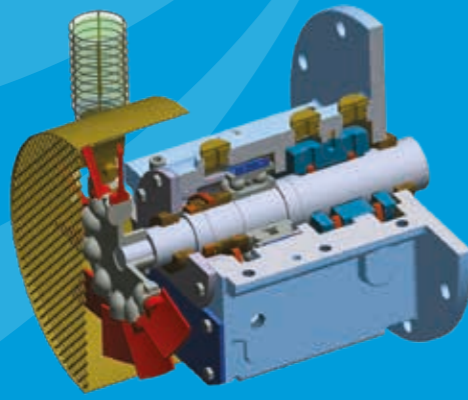

Optional sleeve/ ball bearing assembly

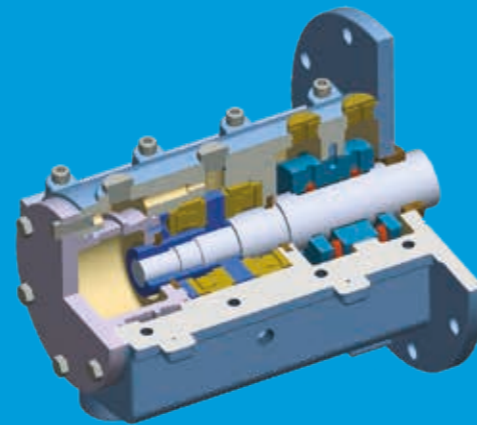

Optional sleeve/tilting pad bearing assembly



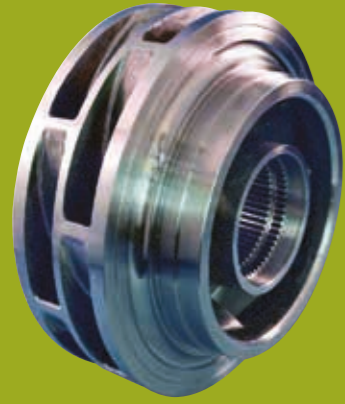

GLOBAL AFTERMARKET CAPABILITY BEST IN SERVICE & RESPONSE

Our customer focused aftermarket organisation is positioned to provide comprehensive care for our varied and diverse product lines. Heritage and obsolete products benefit from the same level of attention and expertise ensuring that reliability and availability is maximised irrespective of a pump's length of service.

GENUINE HIGH QUALITY

Original or upgraded specification spare parts, coupled with full engineering design capability, enables longevity of reliable operation. Highly skilled and experienced service engineers ensure accuracy in build and optimised performance. The worldwide presence of ClydeUnion Pumps offers local service facilities in over 40 countries.

SERVICE SOLUTIONS

Celeros FT is committed to supporting our installed base wherever it may be. Depending on your location we will provide either direct service support or support via our local authorised service partners. Whichever option is provided, you can be assured of the best attention from fully qualified and experienced engineers.

UPGRADES & RE-RATES

- Service & overhaul
- Installation & commissioning
- Technical support
- Inventory management
- 3rd party equipment



Parts & maintenance:

Any brand, any material, anytime. Heritage products, upgrades & improvements



| SPEED
| EXCELLENCE
| PARTNERSHIP



EUROPE

Anncy	P: +(33) 45 005 5600	E: cu.annecy@celerosft.com
Glasgow	P: +(44) 141 637 7141	E: cu.glasgow@celerosft.com

AMERICAS

Baton Rouge, LA	P: +(1) 225 775 2660	E: cu.batonrouge@celerosft.com
Battle Creek, MI	P: +(1) 269 966 4600	E: cu.battlecreek@celerosft.com
Burlington, ON	P: +(1) 905 315 3800	E: cu.burlington@celerosft.com
Calgary, AB	P: +(1) 403 236 8725	E: cu.calgary@celerosft.com
Los Angeles, CA	P: +(1) 562 622 2380	E: cu.downey@celerosft.com
Houston, TX	P: +(1) 281 372 5040	E: cu.houston@celerosft.com

ASIA

Beijing	P: +(86) 10 5926-7000	E: cu.beijing@celerosft.com
New Delhi	P: +(91) 120 4640 400	E: cu.newdelhi@celerosft.com
Shanghai	P: +(86) 21 2208 5888	E: cu.shanghai@celerosft.com
Singapore	P: +(65) 62 76 7117	E: cu.singapore@celerosft.com

Middle East/Africa

Abu Dhabi	P: +(971) 2 408 1900	E: abudhabi.sc@celerosft.com
Dubai	P: +971 4-5289555	E: abudhabi.sc@celerosft.com

Celeros Flow Technology reserves the right to incorporate our latest design and material changes without notice or obligation. Design features, materials of construction, and dimensional data, as described in this bulletin, are provided for your information only and should not be relied upon unless confirmed in writing. Please contact your local sales representative for product availability in your region. For more information, visit www.celerosft.com.

CUP_BB3_224_PB_A4_01/2021 Issued 05/2021

COPYRIGHT © 2021 CELEROS, Inc.