

EDC200 Series Temperature Controller

EDC200 Series temperature controllers are microprocessor-based 1/16 DIN, 1/8 DIN and 1/4 DIN controllers, which provide comprehensive functions and high reliability to monitor and control temperature in various applications. EDC200 Series Support ON/OFF control, Three Position Step Control, and PID algorithm based Time Proportional control with advanced Auto Tuning function provided for PID Parameters optimization.

Specification

Rated Voltage	100 ~ 240V AC, 50/60 Hz or 24V DC
Limit Voltage	85 ~ 264V AC, 47~63 Hz or 19.2 ~ 28.8V DC
Input	TC/RTD, Refer to "Key Parameter Table" for detail
Control Out	SSR drive voltage 24V DC/20mA; N.O. Dry contact / 5A @ 30V DC or 250V AC N.O. Dry contact / 5A @ 30V DC or 250V AC
Alarm Out	0 ~ 55°C
Operative Temperature	-40 ~ 66°C
Storage Temperature	Front Panel: IP54
IP Rate	IEC/EN61010-1
Safety	CAN/CSA-C22.2 No. 61010-1-12 3rd Edition ANSI/UL 61010-1 3rd Edition

Model Selection

- Select the desired Key Number. The arrow to the right marks the selection available.
- Make the desired selections from Table I to Table II. A dot "." denotes availability.

Key Number						Table I			Table II		
E	D	C	2	0	-	-	-	-	-	-	-

Key Number

Description	Selection	Availability
Size		
48 x 48 mm (1/16 DIN), 1x AI, 1x ALM, 1x DI	EDC201	↓
48 x 96 mm (1/8 DIN), 1x AI, 2x ALM, 1x DI	EDC202	↓
96 x 96 (1/4 DIN), 1x AI, 2x ALM, 1x DI	EDC203	↓

Table I

Power	Output	Future
100-240V AC Power	Relay, Dry Contact / N.O., 5A @ 30V DC or 250V AC	
19-28V DC Power	SSR Drive, 24V DC @ 20 mA	

Table II

Future	Future

Technical Assistance Contacts

Support and Contact Information

For Europe, Asia Pacific, North and South America contact details, see back page or refer to the appropriate Honeywell Solution Support web site:

Honeywell Corporate www.honeywellprocess.com

Honeywell Process Solutions <http://www.honeywellprocess.com/en-US/explore/products/instrumentation/panel-mounted-controllers-and-programmers>

Training Classes <http://www.honeywellprocess.com/en-US/training>

Telephone and Email Contacts

Area	Organization	Phone Number
United States and Canada	Honeywell Inc.	1-800-343-0228 Customer Service 1-800-423-9883 Global Technical Support
Global Email Support	Honeywell Process Solutions	hfs-tac-support@honeywell.com

External Size & Installation

Before mounting the controller, refer to the nameplate on the outside of the case and make a note of the model number.

Depth

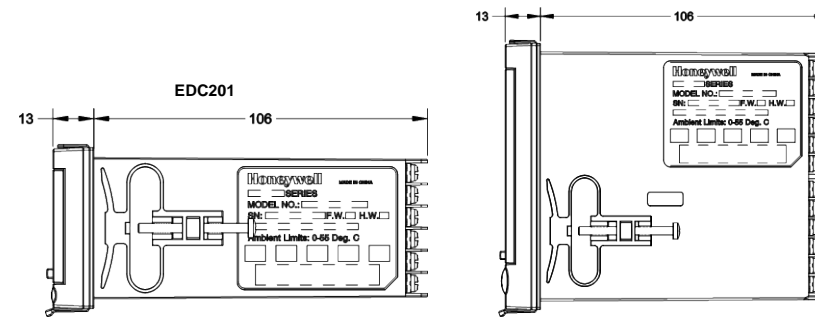

Front Panel Size

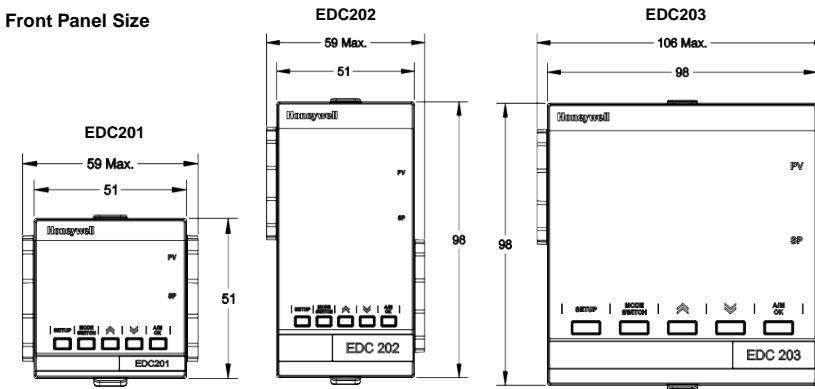

Panel Cutout

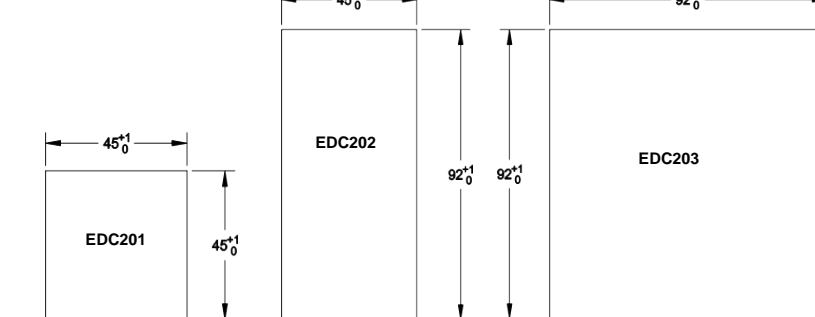

Installation Procedure

- Orient the controller properly and slide it through the panel hole.
- Insert the mounting clamps into the two holes on the left and right side of the case and pull them backwards to hook them up into the case.
- Tighten screws in the mounting clamp to secure the mounting clamp against the panel.

CAUTION: Over tightening may cause damage to the mounting clamp. Less tightening may cause poor sealing performance.

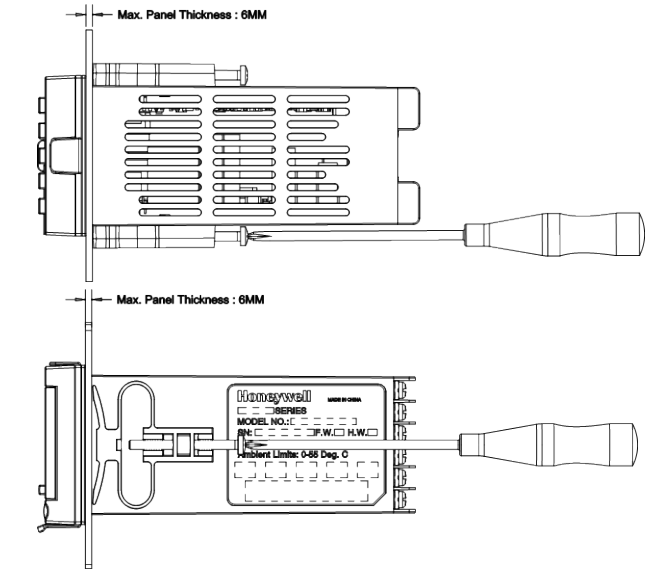

Terminal Wiring Diagram

Confirm the model type you selected first, Then wiring refer to below terminal definition.

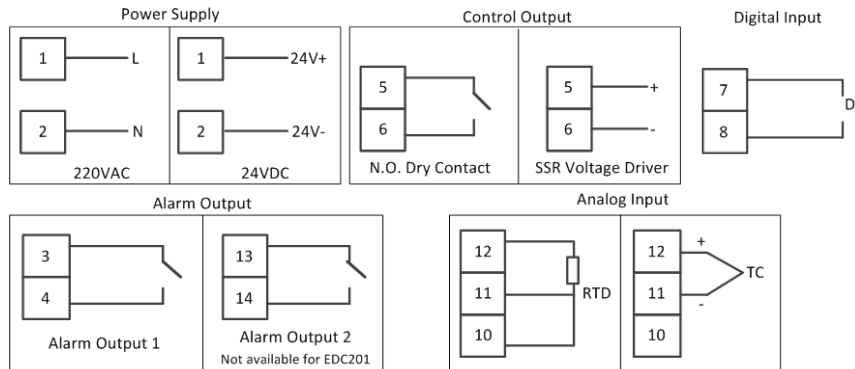

Display & Operation



Area	Display/Button	Normal Operating Mode	Parameter Configuration Mode
1	Menu Navigation	Not display	Current parameter group
2	Temp Unit	Display the unit of current temperature in use	
3	Status Display	Indicate the status of Alarm, control output, control mode and Auto-tuning	
4	Lower Display	Display the value of SP, output and the information of Timer, alarm and auto-tuning	Display the current option or value of the parameter
5	Upper Display	Display the value of process variable	Display the parameter selected
A	SETUP	Press and hold for 3s - Enter into Parameter Configuration Mode	Short press - Switch the Parameter group Press and Hold - Cycle through Parameter Groups
B	MODE SWITCH	Short press - Switch lower display	Short press - Switch parameter; Press and Hold - Cycle through parameters
C	⏏	Increase the value or change the options of selected parameter	
D	⏏	Decrease the value or change the options of selected parameter	
E	A/M OK	Switch control mode when "SP" or "Out" is shown on the lower display; Acknowledge alarm or initiate functions when the information shown on the lower display is other than "SP" and "Out".	Acknowledge actions

Power Up

The system runs self diagnostic during power up process, in case any of the error listed in the right table occurs, the controller goes into failsafe mode and "FAL L" shows up, blinking on the lower display.

Troubleshooting

- Confirm the root cause of the error – Check the 'error code'
 - Press **Setup**. Select **OPTION** Set Up Group. Upper Display = *SEtP*; Lower Display = *EtCd*
 - Press **AM/OK**. Read the error code. Upper Display = *EtCd*; Lower Display = Error code
- If "EC03" is the only error code, follow procedure A; first and then procedure B
- If the error code is other than "EC03", do procedure B

Procedure A: 1. Confirm the wiring of input 2. Confirm the input signal 3. Acknowledge fault

Procedure B: Power cycle the controller
2. Controller goes into normal operating mode and "FAL L" disappears when the system is in Normal Operating Mode; if the system is still in error, please contact Honeywell technical support.

Error Code	Description	Result
ED01	Failure on restoring factory default settings	Goes into Failsafe Mode
ED02	Failure on reading FCT data	
ED03	Failure on reading digital sign	
ED04	Failure on reading configuration data	
ED05	Failure on reading checksum	
ED06	Checksum Comparison error	
ED0A	Failure on reading product code	
FC01	Parameter Configuration error	
FC02	Verification data error	
EC03	Input Failure	

Normal Operating Mode

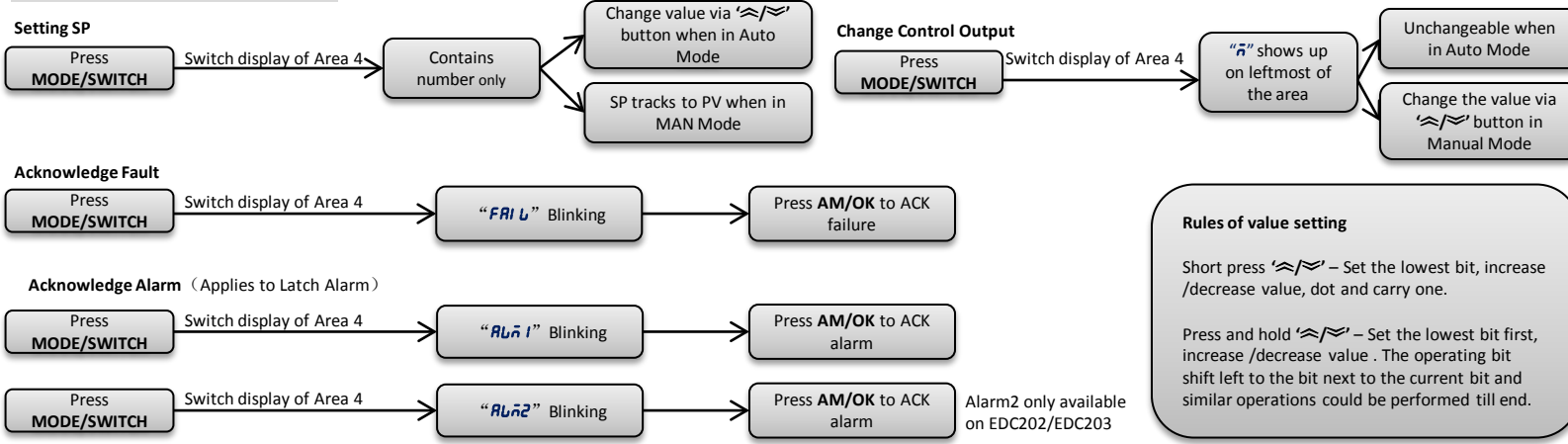

Rules of value setting

Short press *↔* – Set the lowest bit, increase /decrease value, dot and carry one.

Press and hold *↔* – Set the lowest bit first, increase /decrease value. The operating bit shift left to the bit next to the current bit and similar operations could be performed till end.

Parameter Configuration Mode

When in Normal Operating Mode, Press and hold **<SETUP>** for 3s to enter Parameter Configuration Mode.

Please refer to below operating flow for details.

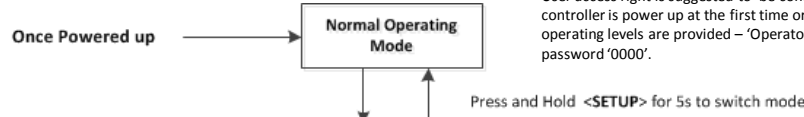

Note: Once the controller is successfully powered up, it will enter normal operating mode and user access right is put to Operator Level. With the operator level, most of the parameters could not be configured.

User access right is suggested to be configured before any other operations when the controller is power up at the first time or factory default setting is recovered. Two operating levels are provided – 'Operator Level' and 'Configuration Level' with the default password '0000'.

Parameter Configuration Flow

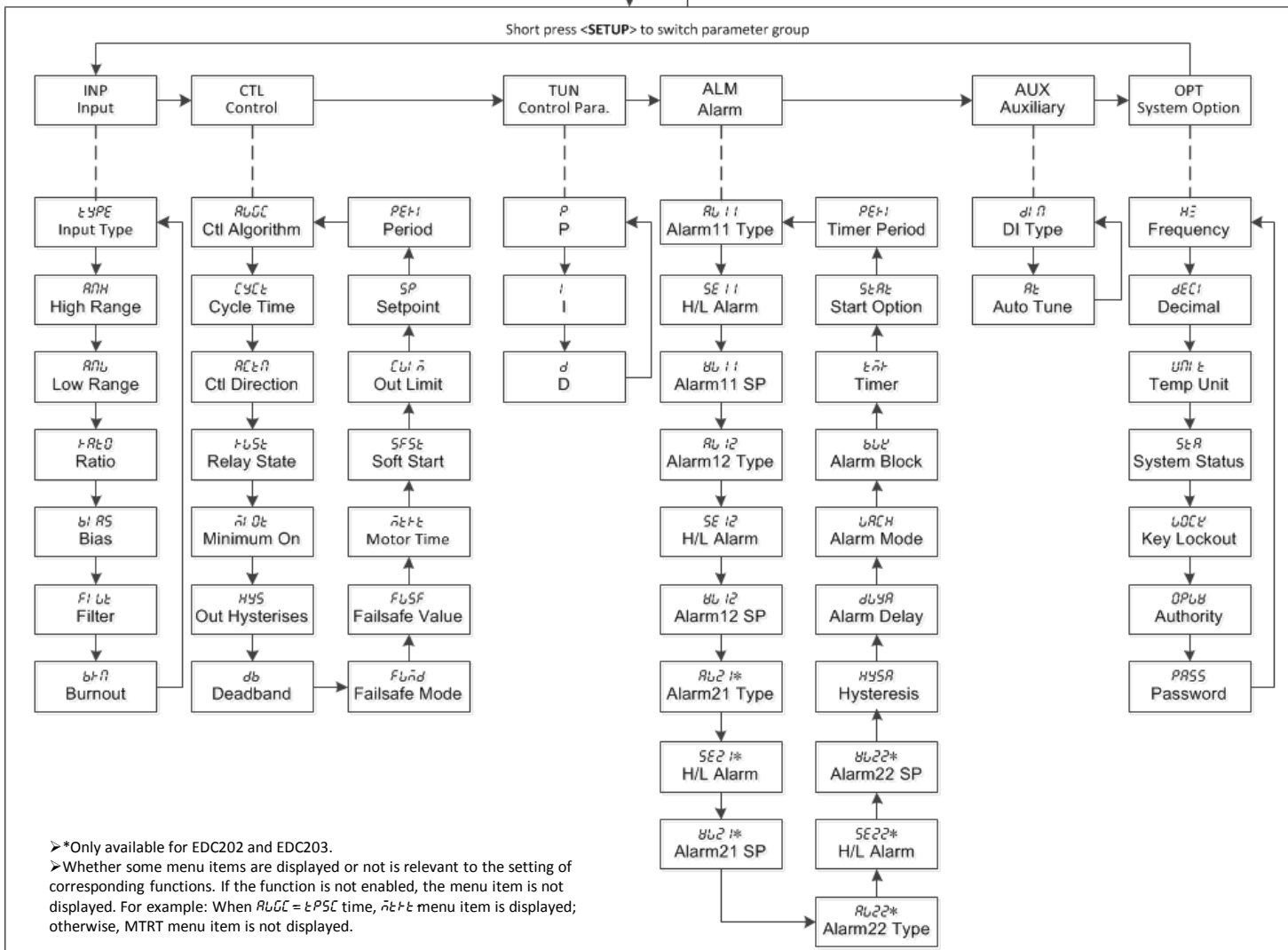

➤*Only available for EDC202 and EDC203.
➤Whether some menu items are displayed or not is relevant to the setting of corresponding functions. If the function is not enabled, the menu item is not displayed. For example: When *ALGC* = *TPSC* time, *SEtP* menu item is displayed; otherwise, *MTRT* menu item is not displayed.

Key Parameter Table

Parameter Group	Parameter	Available Options	Range/Description	
[INP] Input	[TYPE] Input Type		°C	°F
		E [EH]	-270 ~ 1000	-454 to 1832
		NNM [NNMH]	0 to 1371	32 to 2500
		J [JH]	-18 to 871	0 to 1600
		K [KH]	-18 to 1316	0 to 2400
		PL [PLH]	0 to 1380	32 to 2516
		R [RH]	-18 to 1704	0 to 3100
		S [SH]	-18 to 1704	0 to 3100
		T [TH]	-184 to 371	-300 to 700
		PT100 [PTD]	-184 to 649	-300 to 1200
PT100 L [PTDL]	-184 to 149	-300 to 300		
[INP] Input	High Range [ANH]		-999 ~ 9999; The value is generated automatically for TC/RTD sensor types.	
	Low Range [ANL]		-999 ~ 9999; The value is generated automatically for TC/RTD sensor types.	
	Ratio [RATD]		-20.00 ~ 20.00	
	Bias [BIAS]		-999 ~ 9999; Used to compensate the input for drift of an input value due to deterioration of a sensor, or some other causes.	
	Filter [FLTE]		0~120s; A software digital filter is provided for input to smooth the input signal.	
	BURNOUT [BON]	No Failsafe [NOFS]	When input is Burnout, last valid value and alarm are kept on the display	
		Up [UP]	When input is Burnout, the input value is forced to the permissible maximum value.	
		Down [DON]	When input is Burnout, the input value is forced to the permissible minimum value.	
		Failsafe [FS]	When input is Burnout, last valid value and alarm are kept on the display, controller enters failsafe mode.	
	[CTL] Control	Algorithm [ALGC]	ON/OFF [ONFF]	The Process Variable is compared with the set point to determine the output.
		Time A [ETAA]	Time Proportional Control based on PID A algorithm	
		Time B [ETAB]	Time Proportional Control based on PID B algorithm	
		TPSC [TPSC]	The deviation between the estimated motor position and PID out determines the status of the two controller relay outputs through which controls a motor valve open or close. The estimated motor position is "corrected" each time the controller drives the motor to one of its stops (0 % or 100 %).	
Cycle Time [CYCT]			1~120; Used for Time Proportional Control. The unit is 'Second' if the output type is E-M relay and '1/3 seconds' if the output type is SSR driver.	
Control Direction [ACEN]		Reverse [REVS]	The controller's output increases as the process variable increases.	
		Direct [DIRT]	The controller's output decreases as the process variable increases	
Relay State [RLST]		OFF [OFF]	Apply to ON/OFF control and TPSC. The relay is de-energized when the control output at 0%.	
		ON [ON]	Apply to ON/OFF control and TPSC. The relay is energized when the control output at 0%.	
Minimum ON [MIOT]			1 ~ 6 s; specify the minimum duration for digital control output	
Out Hysteresis [HYS]			Define the difference between the value of the process variable at which the control output energize and the value at which they de-energize.	
Deadband [DB]			0.5 ~ 5.0%; The gap between the operating ranges of output 1 and output 2 in which neither output operates. (Apply to TPSC).	
Failsafe Mode [FLSD]		No Latch [NOLA]	Once failsafe, the controller maintains the control mode with the failsafe value.	
		Latch [LA]	Once failsafe, the controller goes to MAN mode with the failsafe value.	
Failsafe Value [FLSF]			The value of control output in failsafe mode	
Motor Time [MTRT]		The time it takes the motor to travel from 0 % to 100 %. This time can usually be found on the nameplate of the motor.		
Soft Start [SFST]		Enable or disable soft start function		
Out Limit [OUTL]		The output limit in Auto mode once the soft start function is activated.		
Set Point [SP]		The soft start process ends once PV reaches the set point.		
Period [PEH]		The soft start process ends once the period set here elapse.		