

ControlEdge PLC – EtherNet/IP

Flexible Deployment and Investment Protection

Product Information Note

ControlEdge™ PLC dramatically reduces configuration, integration, and support costs while decreasing risk with embedded cyber security. Combined with Experion®, it minimizes downtime through unified support, and lowers total cost of ownership through extended system lifecycle. Built-in EtherNet/IP enables integration with a wide range of I/O modules, drives, devices, and controllers supporting the protocol.

Our new programmable logic controller (PLC) is part of the ControlEdge™ family, a next generation family of controllers providing unprecedented connectivity through all levels of process and business operations. The result is optimized operations and maintenance efficiencies that release personnel from manual processes. ControlEdge PLC is one of the first controllers supporting Honeywell's IIoT-ready initiative.

Designed to work with any SCADA system, ControlEdge PLC becomes a superior solution using Experion, leveraging common station hardware and HMI, LEAP project execution, faster field device commissioning, and improved device diagnostics. OPC UA protocol and built-in cyber security provide smooth integration to a range of instruments from multiple vendors. HART-enabled Universal I/O offers remote configuration and late design change flexibility for improved project implementation.

Flexible Architecture design

Built-in EtherNet/IP protocol for ControlEdge PLC supports multiple topologies such as Device Level Ring (DLR), Star, Line and Mixed topology to provide networking flexibility. Network topology flexibility helps in seamless connectivity to devices on new or existing EtherNet/IP networks. Below are some representative examples.

ControlEdge PLCs offer a variety of connectivity options and engineering flexibility with support for a range of I/O devices and controllers. This advanced controller is being certified by ODVA for EtherNet/IP interoperability.



EtherNet/IP™

Flexible engineering and integration enabled by Ethernet/IP communication significantly simplifies system design with components from multiple vendors and reduces the cost of engineering. ControlEdge PLC protects your investment on migration and expansion projects by offering seamless connectivity to existing infrastructure. Industrial facilities will also realize significant value from simplified configuration and

EtherNet/IP Devices and Controller Integration



IO Modules

- Rack based, Din Rail, Block IO
- Namur, IP20, IP76 etc



Sensors

- Process, Flow Meters, Distance Sensors,
- Equipment Monitoring Sensor
- Bar code, RFID



Drives & MCCs

- AC & DC Drives
- Starters
- Motors
- Overload Relays

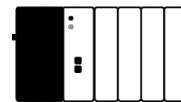

Controllers

- PLC Controllers
- DCS Controllers
- Single Loop Controllers



HMI Panel

- Industrial Panel PC
- LED HMIs

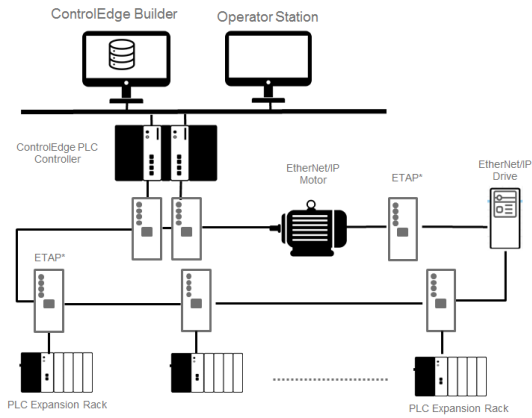

Figure 1 – Ring Topology

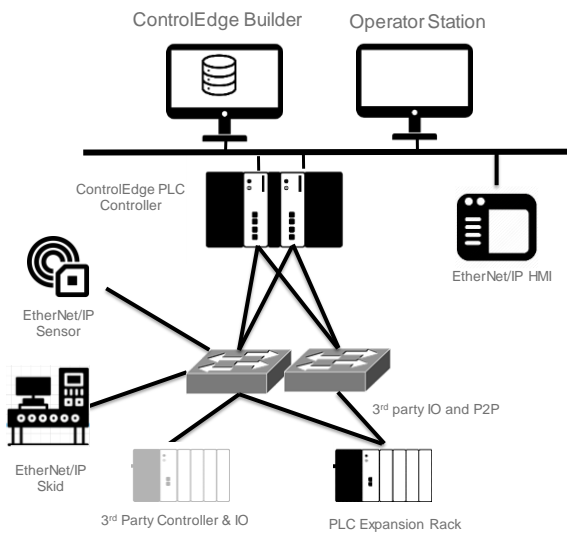

Figure 2 – Star Topology

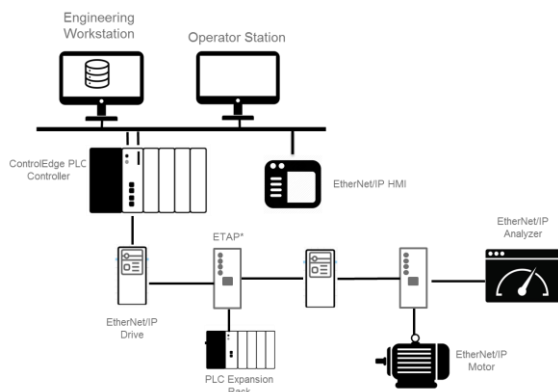

Figure 3 – Linear Topology

Key Features

- EtherNet/IP Server and Client
- Class 1 and Class 3 messaging
- Peer to Peer communication with EtherNet/IP controllers
- 20ms-3200ms RPI
- Support generic EtherNet/IP Modules
- Electronic Keying – Comparison of device version in builder and installed device
- Ethernet/IP and 900 IO modules support on same network
- Multi-vendor I/O device and controller integration
- ODVA Certification

Connectivity

Several device vendors support EtherNet/IP protocol and are certified by ODVA. With support for EtherNet/IP client and Server, ControlEdge PLC can connect with a range of EtherNet/IP devices and controllers using implicit and explicit messaging. A wide range of applications can be delivered by leveraging connectivity to drives, Motor Control Centers, IO modules, valves, sensors, an HMI panel, and more. Multi-Vendor devices can be efficiently integrated due to connectivity based on standard open protocol. Engineers get a wide range of design choices, be it for topology, vendor, specifications or connection media, to deliver a solution to fit application requirements. Standard data models for accessing the process and device information significantly improve information available for controls and diagnostics.

Built in EtherNet/IP Server and Client

Hardware cost is reduced with a PLC system supporting multiple protocols on the same controller. ControlEdge PLC becomes more powerful with the addition of built in EtherNet/IP Server and Client functionality on the CPM (Control Processor Module). Locating the server and client on different Ethernet ports provides isolation between server and client devices connected to PLC. Moreover, using ControlEdge PLC as the EtherNet/IP server offers cyber security.

A combination of 900 I/O modules and EtherNet/IP devices can be connected to the CPM, providing engineers with an additional level of flexibility on I/O network design.

ODVA Certification

ControlEdge PLC is certified by ODVA for conformance to EtherNet/IP standards and interoperability with other certified devices



Figure 5- ControlEdge PLC CPM

Scalable to a Broad Range of Applications

Honeywell's PLC solution enables you to configure a control system with functionality to suit your specific needs. The controllers are scalable not only in their speed of processing, but also in their performance characteristics. In addition, they offer networking options across different communication standards.

ControlEdge PLC is designed to control equipment and processes used in water and waste water treatment, chemicals, mining, metals and minerals, power generation, food & beverage, and the Oil and Gas industry. It is also ideal for process industry applications such as instrument air handling, coal and ash handling, chiller controls, and drying equipment.

Expert Service & Support

Honeywell has been recognized as an automation industry leader for more than four decades. Our technology is installed in some of the largest refineries, plants, mills and mines in the world. Honeywell automation systems are easy to install and use, and are the most reliable and scalable systems available. Total Care and SESP service offerings are available for ControlEdge PLC. Refer to the Total Care PIN for more details.

An application migration tool, ControlEdge Transition R100, is now available for Rockwell legacy PLC migration to ControlEdge PLC. It includes extensive pre- and post-migration reports; the result is an improved project schedule.

Honeywell understands that knowledgeable support and implementation services—delivered when and where they're needed—are critical to the success of any automation project.

For More Information

Learn more about ControlEdge PLC – Easy Integration and Flexible Deployment at our website www.honeywellprocess.com/PLC or contact your Honeywell account manager.

Honeywell Process Solutions

1250 West Sam Houston Parkway South
Houston, TX 77042

Honeywell House, Skimped Hill Lane Bracknell,
Berkshire, England RG12 1EB UK

Building #1, 555 Huanke Road, Zhangjiang Hi-Tech
Industrial Park, Pudong New Area, Shanghai 201203

www.honeywellprocess.com

Experion® is a registered trademark, and ControlEdge™, DSA™ and LEAP™ are trademarks of Honeywell International Inc.