

Pressure-Limiting Valve 200-50B

Bulletin SS03015 Issue/Rev. 0.4 (8/17)

Smith Meter® Valves

The **Smith Meter® Model 200-50B Valve** is a hydraulically-operated, diaphragm-actuated, globe-pattern, automatic pressure reducing control valve. It is designed to provide a steady downstream pressure, regardless of fluctuations in the system upstream pressures.

Features

- **Field-adjustable** – adaptable to customer requirements.
- **Automatic operation** – for worry-free service.
- **Simple construction** – reduces maintenance downtime.
- **Versatile** – suitable for horizontal or vertical applications and may be combined with other Smith Meter pilots to provide multiple control functions.

Principle of Operation

The Smith Meter Model 200-50B regulates system pressure by sensing the downstream pressure at the outlet side of the valve with an integral sense line.

The Model 50B is a normally-open pilot installed in the downstream side of the pilot loop. The 200-50B will allow product flow as soon as there is sufficient upstream pressure to overcome the main valve spring-pressure. When downstream pressure approaches the predetermined setting of the 50B pilot, the pressure builds up beneath the pilot diaphragm, overcoming the pilot spring pressure and restricting the main valve cover vent path through the pilot seat orifice. This restriction causes the partial closing of the main valve due to the increase in upstream pressure within the main valve cover chamber (see Figure 1). The 200-50B automatically responds to changes in system demands and will allow an increase in downstream pressure as required.

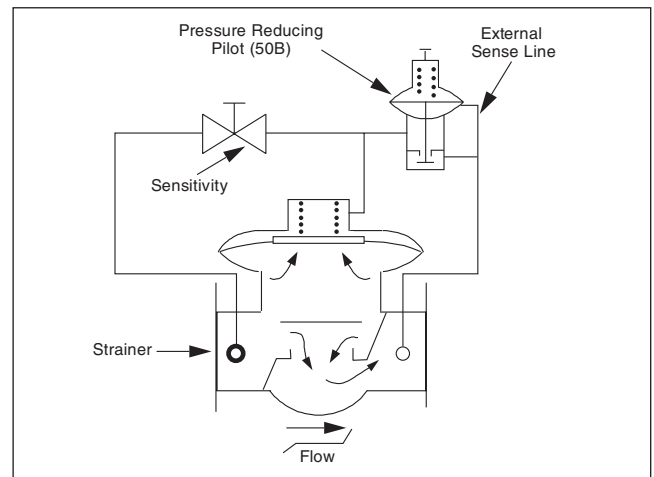

Figure 1 – Model 200-50B (Throttling)

Applications

The Smith Meter Model 200-50B is a modulating control valve that can be used in most non-dead-end service system designs where protection of downstream equipment from excessive pump pressure is required.

The control range of the Model 200-50B is limited to flow rates above 2% of the nominal maximum flow.

Additional control functions can be added to the 200-50B pressure-reducing control valve. Included are solenoid block (Model 30A), rapid shutdown (Model 30B) maximum rate-of-flow control (Model 40A), back-pressure control (Model 60A) and check and thermal relief (Model 80B/07).

Specifications

Nominal Flow Ratings

Size	Flow		Cv*
	USGPM	L/min	
2"	130	492	50
3"	420	1,600	133
4"	600	2,250	204
6"	1,000	3,750	436

+ Pressure Drop: $DP \text{ (psi)} = \text{Sp. Gr.} \left(\frac{Q(\text{USGPM})}{Cv} \right)^2$

Maximum Product Viscosity

200 SSU (40 mPa·s). Above 200 SSU, consult factory.
 1 mPa·s = 1 cP.

Pressure Rating

Class 150 ANSI, 285 psi (19.6 bar).
 Class 300 ANSI, 300 psi (20.7 bar).
 At 100°F (37.8°C), derate per ASME B16.5.

Materials of Construction

Component	Body	Internals	Seals
Model 200	Carbon Steel	Stainless Steel, Carbon Steel, Ductile Iron	Buna-N or Viton
09SC Strainer	Carbon Steel	304 Stainless Steel	–
Needle Valve Model 13	Carbon Steel	Stainless Steel, Carbon Steel	Viton O-ring w/PTFE Backup ¹
50B	Carbon Steel	300 Stainless Steel, Carbon Steel	Viton (Std.), Buna

Temperature Range

Seal Material		Temperature Range
Diaphragm Valves	Pilots	
Buna-N ⁺	Viton ⁺	0°F to 160°F
Viton	Viton ⁺	10°F to 350°F

+ Standard; for other elastomers, consult factory.

Weight

Model	Size	Weight – lb (kg)
200-50B	2"	48 (22)
	3"	85 (39)
	4"	138 (63)
	6"	260 (118)

Ordering Information

Operating Conditions	Liquid – name and sp. gr., or API gravity, temperature range*, viscosity range*, maximum working pressure, and pressure settings.
Seals	Buna-N, Viton

* Minimum, normal and maximum.

Dimensions

Inches (mm)

Model	Size	A Class 150	A1 Class 300	B ⁺	C	D ⁺	E
200-50B	2"	8.0 (203)	8.5 (216)	8.0 (203)	4.0 (102)	7.5 (140)	3.0 (76)
	3"	11.0 (279)	11.8 (299)	9.5 (241)	4.0 (102)	9.5 (241)	4.1 (105)
	4"	13.5 (343)	14.2 (362)	9.5 (241)	4.9 (124)	9.5 (241)	4.5 (114)
	6"	17.0 (432)	17.9 (454)	11.0 (279)	6.6 (168)	12.5 (318)	5.5 (140)

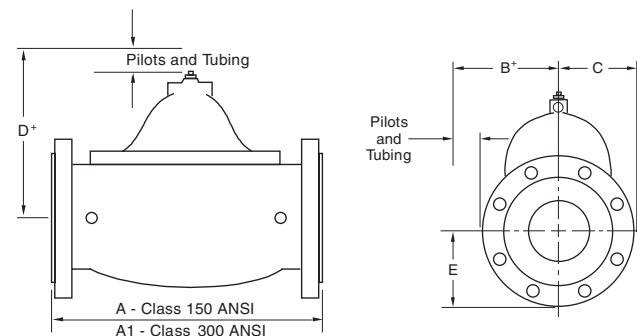

Note: Dimensions – Inches to the nearest tenth (millimetres to the nearest whole mm), each independently dimensioned from respective engineering drawings.

+ Pilots and tubing will be within these dimensions.

¹ Polytetrafluoroethylene (PTFE).

The specifications contained herein are subject to change without notice and any user of said specifications should verify from the manufacturer that the specifications are currently in effect. Otherwise, the manufacturer assumes no responsibility for the use of specifications which may have been changed and are no longer in effect.

Contact information is subject to change. For the most current contact information, visit our website at www.fmctechnologies.com/measurementsolutions and click on the "Contact Us" link in the left-hand column.

TechnipFMC.com

FMCTechnologies.com/MeasurementSolutions

© TechnipFMC 2017 SS03015 Issue/Rev. 0.4 (8/17)

TechnipFMC
 FMC Technologies
 Measurement Solutions, Inc.
 500 North Sam Houston Parkway West,
 Suite 100
 Houston, Texas 77067 USA
 P:+1 281.260.2190

USA Operation
 1602 Wagner Avenue
 Erie, Pennsylvania 16510 USA
 P:+1 814.898.5000

Germany Operation
 Smith Meter GmbH
 Regentstrasse 1
 25474 Ellerbek, Germany
 P:+49 4101.304.0