

12" Steel Model K12

Bulletin SS01020 Issue/Rev. 1.1 (12/21)

Smith Meter® Crude Transportation (CT) Series Positive Displacement (PD) Meter

The Smith Meter Model K12 Meter is a 12", double-case, straight-through-type, rotary vane, positive displacement flow meter and is part of the CT series of large PD meters.

The CT series PD Meters incorporate design features including lightened blades, full-width wear strips, and tungsten carbide roller pins to provide extended service in harsh crude applications.

The crude transportation series is suitable for both crude oil and refined product applications such as blending, batching and leak detection as well as traditional custody transfer applications.



Generic Illustration

Options

- High-viscosity meter clearances extend operation at maximum flow rate from 200 to 2,000 millipascal-second (mPa•s).
- High-temperature clearances extend operating temperatures from 115 to 200 degrees Fahrenheit (°F) (46 to 93 degrees Celsius (°C)).
- All iron trim option for operating temperatures above 200 °F (93 °C).
- Liquefied petroleum gas (LPG) trim option for low-lubricity liquids, such as LPG.
- Compliant with NACE standard MR-01-75.
- ASME Section VIII vessel construction is available for model K12-S3.

Operating Specifications

Maximum Flow Rate

	BPH	m ³ /h
Continuous rating with standard trim	7,200	1,140
Continuous rating with all iron or LPG trim	5,400	855

Barrels per hour (BPH) and cubic meters per hour (m³/h)

Minimum Flow Rate Typical Performance

Linearity ¹	Units	Viscosity (Centipoise—mPa•s)				
		1	2	20	100	200
±0.15%	BPH	650	260	65	16	8
	m ³ /h	103	41	10	2.5	1.3
±0.25%	BPH	500	200	50	12	6
	m ³ /h	80	32	8	1.9	0.9
±0.50%	BPH	325	130	33	80	4
	m ³ /h	52	21	5	1.3	0.6

¹ Based on a maximum flow rate of 7,200 BPH (1,140 m³/h).

Repeatability

±0.02%

Viscosity

Standard: 200 mPa·s² (1,000 Seconds Saybolt Universal (SSU)) maximum

Optional: 2 pascal seconds (Pa·s) (10,000 SSU) maximum, specify "high viscosity meter clearances."

Over 2 Pa·s: Specify "high viscosity meter clearances" and derate maximum flow rate in direct proportion to viscosity over 2 Pa·s. For example, at 4 Pa·s, derate maximum flow rate to 50% of normal continuous rating 3,600 BPH.

Temperature

Standard meter clearances with:

Buna N: -20 °F to 115 °F (-29 °C to 46 °C)

FKM⁶: 10 °F to 115 °F (-12 °C to 46 °C)

Low temp. FKM^{6,7}: -50 °F to 115 °F (-46 °C to 46 °C)

High temperature meter clearances with:

Buna N: -20 °F to 200 °F (-29 °C to 93 °C)

FKM⁶: 10 °F to 200 °F (-12 °C to 93 °C)

Low temp. FKM^{6,7}: -50 °F to 200 °F (-46 °C to 93 °C)

All iron trim with:

Buna N: -20 °F to 225 °F (-29 °C to 108 °C)

FKM⁶: 10 °F to 400 °F (-12 °C to 205 °C)

Low temp. FKM^{6,7}: -50 °F to 400 °F (-46 °C to 205 °C)

Meter Gearing

One barrel or 1 hectolitres per revolution of meter calibrator output shaft.

Fifty gallons—Special.

Maximum Working Pressure			
Model	Flange	PSI	kPa
K12-S3	150	285 ⁴	1,765 ⁴
K12-S6	300	740 ⁴	5,102 ⁴
K12-S7	600	1,480 ⁴	10,204 ⁴

Flange class per ANSI B16.5 raised-face flange.

² 1,000 mPa·s = 1,000 cP = 1 Pa·s

³ Polytetrafluoroethylene (PTFE)

⁴ Maximum working pressure at 100 °F (38 °C)

⁵ Standard

⁶ Fluoroelastomer (FKM)

⁷ Only available for K12-S3 with low temperature material and Section VIII design. Low temperature FKM is the standard sealing material for meters with the ASME Section VIII design.

Pressure Drop (ΔP)

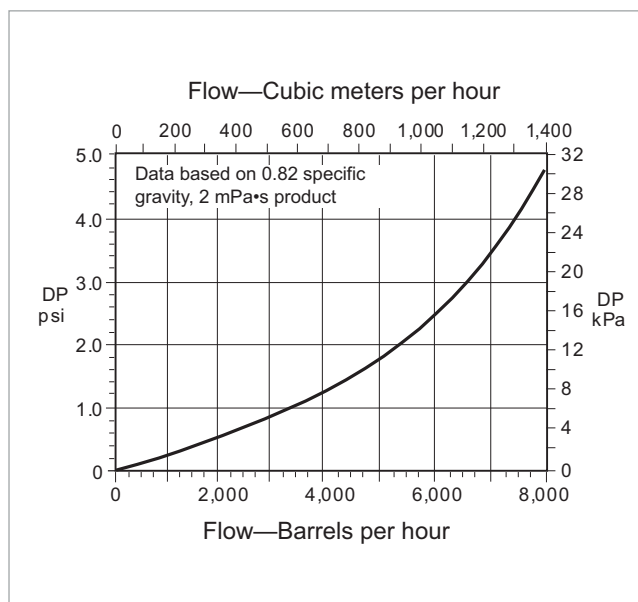

Materials of Construction

Trim	Housing	Internals	Seals
Standard	Steel	Iron, steel, stainless steel, aluminum	Buna N ⁵ , FKM ⁶ , low temp. FKM ^{6,7} , or PTFE ³
LPG	Steel	Iron, steel, stainless steel, aluminum, rulon, nylon	Buna N ⁵ , FKM ⁶ , low temp. FKM ^{6,7} , or PTFE ³
All Iron	Steel	Iron, steel, stainless steel	Buna N ⁵ , FKM ⁶ , low temp. FKM ^{6,7} , or PTFE ³

Installation

It is recommended that the meter be protected with a suitable mesh strainer.

Weights and Measures Approvals

Brazil—INMETRO Dimel No. 0148

EU—PTB Issued MID (Measuring Instrument Directive)

PTB Issued OIML R117 Test report

Russia—GOST

For other, consult factory.

Pressure Safety Requirements

PED—Pressure Equipment Directive (EU)

CRN—Canadian Registration Number

For other, consult factory.

Catalog Code

The following guide defines the correct PD meter for a given application and the respective catalog code. This code is part of the ordering information and should be included on the purchase order.

1	2	3	4	5	6	7	8	9	10
K	K	12	S	3	G	B	S	0	0

Position 1: Code

K—Catalog Code

Positions 2 and 3: Model/Flange Size

K12—12"

Position 4: Flow Path

S—Straight

Positions 5: Pressure Class and End Connections

Standard (Raised-Face Flanges)

3—Class 150, 285 psig/1,965 kPa

6—Class 300, 740 psig/5,102 kPa

7—Class 600, 1,480 psig/10,204 kPa

8—Class 900, 2,220 psig/15,306 kPa

PED (Raised-Face Flanges)⁹

3—Class 150, 285 psig/1,965 kPa

6—Class 300, 740 psig/5,102 kPa

7—Class 600, consult factory

All flanges designed to ANSI B16.5, pressure ratings maximum working pressure at 100 °F.

Position 6: Meter Gearing

G—Gallons (5:1 - S3)

B—Barrels (1:1 - S3 through S8)

D—Dekaliters (1:1 - S3 through S8)

I—Imperial gallons⁸

P—Pound⁸

Position 7: Seals

B—Buna N

L—Low temperature FKM^{6,7}

T—PTFE³

V—FKM⁶

Position 8: Trim

S—Standard

A—All iron

L—LPG

Position 9: Temperature Compensation

0—None

A—ATC

B—ATG

Position 10: Special Requirements

0—Standard

C—CRN and low temperature material⁷

L—Low temperature material⁷

P—PED (consult factory)⁹

³ Polytetrafluoroethylene (PTFE).

⁶ Fluoroelastomer (FKM).

⁷ Only available for K12-S3 with low temperature material and Section VIII design. Low temperature FKM is the standard sealing material for meters with the ASME Section VIII design.

⁸ Consult factory for model number when selecting imperial or pound gearing.

⁹ PED required for all European countries. Equipment must be manufactured by Ellerbek, Germany facility.

Dimensions

Inches (millimeters)

Note: Dimensions—Inches to the nearest tenth (millimeters to the nearest whole mm), each independently dimensioned from respective engineering drawings.

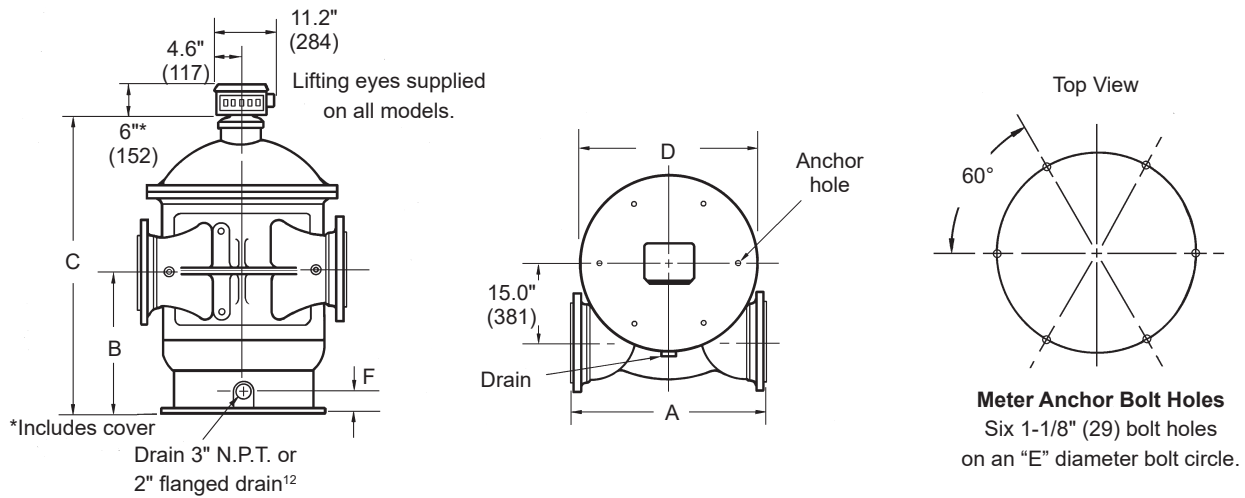

Model	A	B	C	D	E	F	Weight lb (kg)
K12-S3	38.0" (965)	26.0" (660)	54.3" (1,379)	35.5" (902)	27.0" (686)	3.3" (84)	3,025 (1,372)
K12-S3 Low Temp. Material ⁷	38.0" (965)	26.0" (660)	55.71" (1,415)	37.88" (962)	27.0" (686)	3.5" (89)	3,650 (1,656)
K12-S6	46.3" (1,076)	26.3" (667)	56.8" (1,443)	40.5" (1,029)	30.0" (762)	3.3" (84)	4,830 (2,191)
K12-S7	48.8" (1,240)	28.2" (716)	60.6" (1,539)	42.5" (1,080)	30.0" (762)	3.3" (84)	10,644 (4,828)

Ordering Information

Application	Batching, loading, blending, inventory, process control, etc.
Operating Conditions	Liquid—Name and specific gravity, flow range ¹⁰ , viscosity range ¹⁰ , maximum working pressure
Seals	Buna N ¹¹ , FKM ⁶ , or low temperature FKM ^{6,7}
Units of Registration	Gallons, barrels, cubic meters, tons
Direction of Flow	Left to right flow (as viewed above) is standard and will be supplied unless right to left flow is specified
Options and Accessories	As required

3 Polytetrafluoroethylene (PTFE).

6 Fluoroelastomer (FKM).

7 Only available for K12-S3 with low temperature material and Section VIII design. Low temperature FKM is the standard sealing material for meters with the ASME Section VIII design.

9 PED required for all European countries. Equipment must be manufactured by Ellerbek, Germany facility.

10 Specify minimum/normal/maximum.

11 Standard seals supplied unless optional material specified.

12 All meters have 3" NPT drain as standard and 2" RF flanged drain as an option. K12-S3 ASME Section VIII has a 2" 150# RF flanged drain as a standard 20.43" (513 mm) between the meter's center line and the drain flange's face.

Accessories

Counters

- 200 Series—Accumulative, 9-digit, non-reset type
- 600 Series—Large 5-digit reset, small 8-digit non-reset

Electronic Pulse Transmitters

LNC pulse transmitter (adapts to 600 Series counters)

- Low resolution—1 or 10 pulses¹³
- High resolution (HR)—50 or 100 pulses¹³

UPT

Universal Pulse Transmitter—High resolution dual pulse quadrature output in a weather-tight explosion-proof enclosure (up to 1000 pulses/rev) used to provide pulse inputs to optional electronic indicators/controllers/flow computers which may perform electronic temperature compensation.

Flow Rate Indicator

- Direct mount mechanical
- Remote electronic—MMRT-II (see specifications [SS09045](#))

Remote Registration

- Electronic totalizers—MMRT-II (see specifications [SS09045](#))

Mechanical Automatic Temperature Compensation

- Model ATC—Factory-set for a given product
- Model ATG—Field-adjustable for different products

¹³ Per revolution of LNC right-hand wheel

Revisions included in SS01020 Issue/Rev. 1.1 (12/21):

K12-S3 ASME Section VIII low temperature material information added.

The specifications contained herein are subject to change without notice and any user of said specifications should verify from the manufacturer that the specifications are currently in effect. Otherwise, the manufacturer assumes no responsibility for the use of specifications which may have been changed and are no longer in effect.

USA Operation
1602 Wagner Avenue
Erie, Pennsylvania 16510 USA
P:+1 814.898.5000

TechnipFMC
13460 Lockwood Road
Building S01
Houston, Texas 77044 USA
P:+1 281.591.4000

Germany Operation
Smith Meter GmbH
Regentstrasse 1
25474 Ellerbek, Germany
P:+49 4101 304.0