



Installation Guide

Release R210

TABLE OF CONTENTS

CHAPTER 1 Storage, Unpacking and Handling 1-1

 1.1 Unpacking and Inspection 1-1

 1.2 Storage 1-1

 1.3 Handling 1-1

CHAPTER 2 Safety 2-1

 2.1 Safety Conventions 2-1

 2.2 Safety Instructions for the CIU888. 2-2

CHAPTER 3 Mechanical Installation 3-1

 3.1 General 3-1

 3.2 Specifications and operational requirements. 3-1

 3.3 Environmental requirements 3-1

 3.4 Mechanical installation 3-3

 3.5 Electrical installation 3-3

 3.6 Mounting 3-3

CHAPTER 4 Electrical Installation. 4-1

 4.1 Electrical specification 4-1

 4.2 Grounding 4-1

 4.3 Mains 4-1

 4.4 CIU 888 Interface Summary 4-3

 4.5 Field and Host Port Connections. 4-4

 4.6 Host RS232-485 Ports (MODBUS Output) 4-10

 4.7 Ethernet Ports 4-10

 4.8 USB Ports 4-11

 4.9 VGA Port (Optional Interface) [Part of a future release] 4-11

 4.10 Audio Port [Part of a future release] 4-11

 4.11 Audio Plug and Signal Details [Part of a future release] 4-11

 4.12 Relay or DO Outputs [Part of a future release] 4-12

 4.13 Key Locks 4-13

 4.14 User Interface 4-13

CHAPTER 5 Appendix A: List of Spares and Accessories 5-1

 5.1 List of Spares and Accessories 5-1

Table of Contents

This page is intentionally left blank

CHAPTER 1 STORAGE, UNPACKING AND HANDLING

1.1 Unpacking and Inspection

Check the identification code on the label to verify that the CIU 888 was delivered in accordance with your order.

The CIU 888 is packed in a shipping carton for protection against damage. If you find any shipping or handling damage at delivery or during unpacking, immediately notify the carrier. If any equipment is missing or incorrect, notify the Honeywell Enraf distributor.

As soon as you receive the box, open it and check the contents right away.

Check the contents against the factory checklist and not only from the type plate.

1.2 Storage

Store the CIU 888 in its original packing indoors in a safe, dry place. Storage temperature may vary between -20 °C and +85 °C (-4 °F and +181 °F).

1.3 Handling

Handle the CIU 888 with care. When handling or carrying it, be aware of the front panel that can open and be damaged.

The CIU 888 unit weighs about 6 kg. The recommended way to carry the unit is by holding it from the front and rear side.

This page is intentionally left blank

CHAPTER 2 SAFETY

2.1 Safety Conventions

2.1.1 Warnings

The following warning symbol used in the manual recommends your attention ***to prevent personal injuries or dangerous situations.***

Symbol	Description	Remark
	General warning	It is always explained by text.

2.1.2 Cautions

The following caution symbol used in the manual recommends your attention ***to prevent damages to the equipment.***

Symbol	Description
	General caution sign

2.2 Safety Instructions for the CIU888

2.2.1 General



WARNING! *You must strictly follow the safety instructions mentioned in this manual and the safety instructions shipped with the device for installation, operation, and maintenance, for the safe operation of the CIU device.*



WARNING! *Disconnect supply before servicing.*



AVERTISSEMENT! *Couper l'alimentation avant l'entretien et le dépannage.*

1. CIU 888 device has to be installed and serviced by a trained person only.
2. The entire installation procedure for the CIU must be implemented in accordance with national, local, and company regulations.
3. See section 3.3 "Environmental requirements" for more information.
4. Do not open the top cover when the device is powered on. See the Troubleshooting and Maintenance Manual CIU 888 (Part No. 4417594) for more information.
5. If the device is not installed and used as described in the manual, the protection provided by CIU888 may be impaired.

This page is intentionally left blank

CHAPTER 3 MECHANICAL INSTALLATION

3.1 General

Observe country, local and company regulations during all steps of the installation.

Only qualified technicians must perform the installation.

Honeywell Enraf accepts no responsibility caused by mis-handling, mis-use or faulty operation of the CIU 888.

3.2 Specifications and operational requirements

Sl. No.	Measure	Value	Units
CIU 888 unit			
1	Dimensions (l x b x h)	400 x 283 x 94	mm
		15 ¾ X 11 ½ x 3 ⅝	in
2	Height	2U	
3	Weight (without mounting accessories)	6	kg
		15.43	lb
Wall mount			
1	Wall Mount Base Plate		
	(l x b x h)	267 x 455 x 84	mm
2	Horizontal mounting hole pitch	186	mm
3	Vertical mounting hole pitch	110	mm

3.3 Environmental requirements

Environmental requirements	
Ambient Temperature	0 °C to +60 °C (+32 °F to +140 °F)
Storage Temperature	-20 °C to +85 °C (-40 °F to +185 °F)
Enclosure Classification	IP 40 (NEMA 1)*
Humidity	0% to 90% non-condensing
Altitude	Up to 2000 meters
EMC Class	CLASS A

* Evaluated by Honeywell.

3.3.1 CIU 888 Dimensions

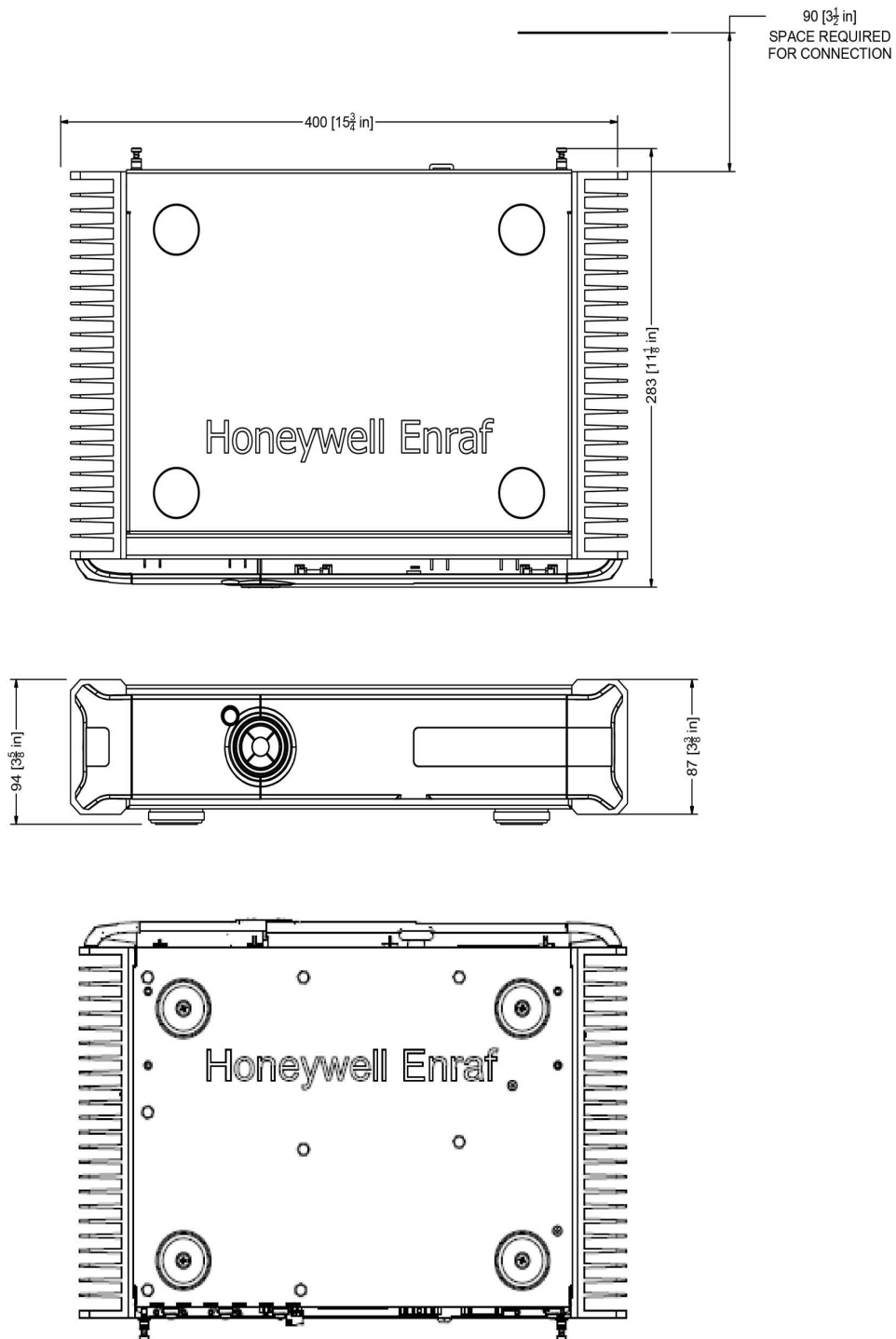

FIGURE 3-1

CIU 888 dimensions

3.3.2 Operational requirements

CIU 888 is provided with an advanced and efficient cooling system using a heat pipe. For its operation, its ambient operating temperature is 0 to 60 °C. That is, the temperature around both heat sinks in any type of operation - desktop, rack mount, or wall mount needs to be in this range.

3.4 Mechanical installation

Safety grounding

Pull reliefs (signal cabling)

All M6 (low carbon steel) screws to secure the CIU 888 to the rack maintain torque values between 3.4 Nm to 4.6 Nm [30.1 lbs-in to 40.7 lbs-in].

3.5 Electrical installation

Check if the fuse is intact.

Check if the Key(s) for the Key Lock Switches are available.

Marking of ports and cables. The CIU 888 is grounded via the earth wire of the mains cable and an external ground terminal is provided, which is located at the rear side next to the mains power entry.

3.6 Mounting

You can mount the CIU 888 can in three different ways.

- Table top or desktop use
- 19" rack mount
- Wall mount

In any case, the front panel of the CIU 888 must be freely accessible. The front panel includes the LCD display, user keys, ring of light, service port, reset switch, key switches, etc., all of which must be freely accessible.

NOTE: Dimensions indicated in all drawings in this manual are in metric and imperial units.

3.6.1 Table Top usage

The CIU 888 is placed on the desk or a table top. This does not require any special attachment.

Place the CIU 888 on a flat surface. Do not place anything on top of the unit. Stacking another CIU 888 on top is acceptable. Make sure visibility

and accessibility of the front panel and cabling at the rear are not obstructed.

3.6.2 Rack Mounting

For rack mounting a set of 2 rack mounting brackets or ears is required. If you have not ordered it from the factory, you can order it anytime as an accessory. See the accessory list provided in this manual.

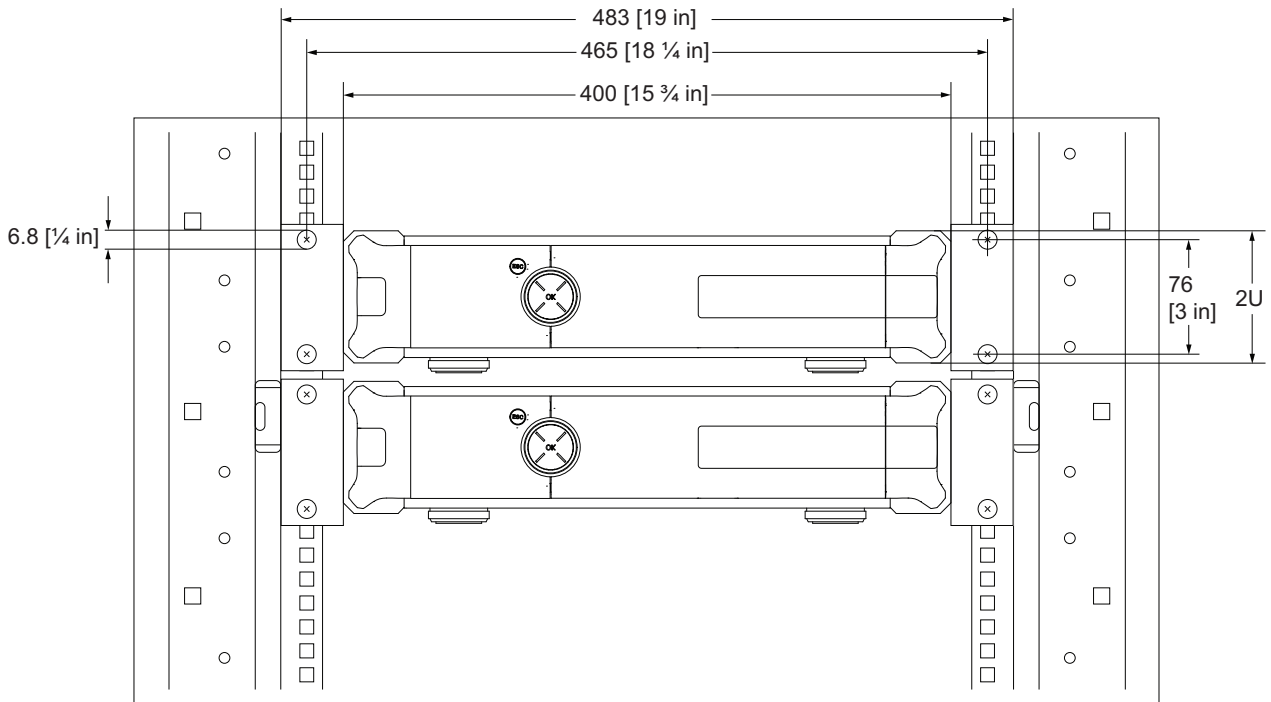

FIGURE 3-2

Rack Mounting

The steps below show the rack mount bracket assembly with the unit.

1. Fix the left bracket (provided as part of rack mount accessories) on the bottom of the CIU 888 by fastening the screws. Repeat the same process for fixing the right bracket on the other side.

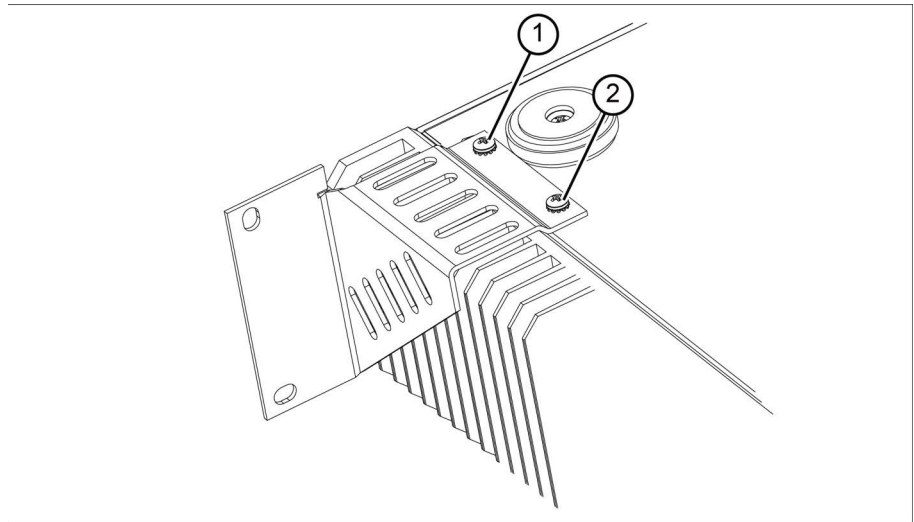

FIGURE 3-3

Fixing the Brackets

2. Mount the CIU 888 on the rack and align the screws to the holes.

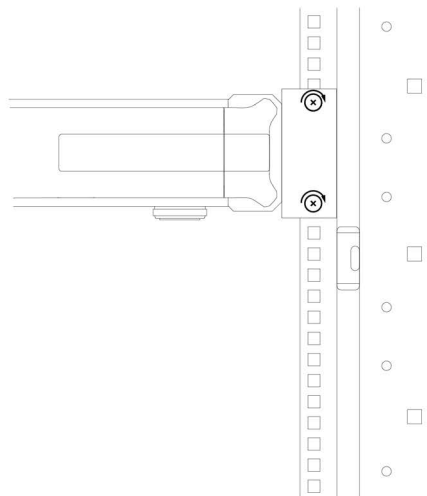

FIGURE 3-4

Align with Rack Holes and tighten the screws

3. Once all the four screws are in place, secure them tightly using a torque of 4.6 Nm (40.7 in lbs) when using a low carbon steel M6 screw.

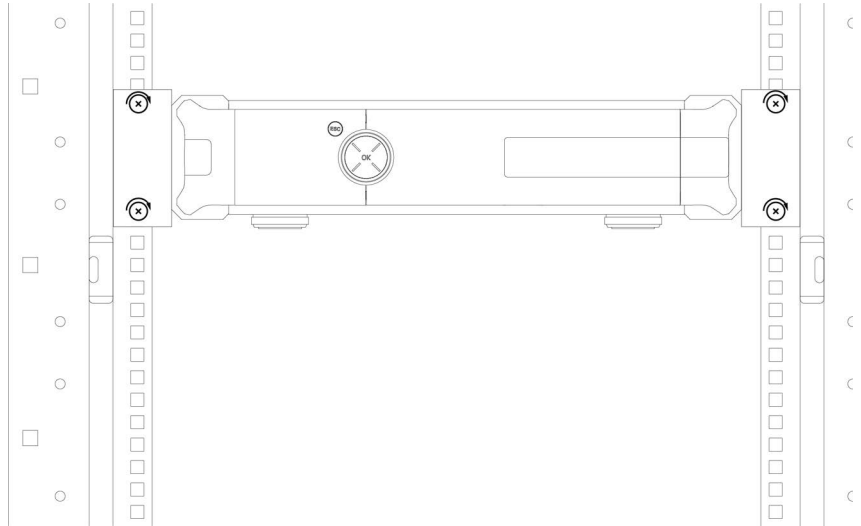

FIGURE 3-5

CIU 888 assembled in a 19" Rack

3.6.3 Wall Mounting

You will need a wall mounting kit for wall mounting CIU 888. If you have not ordered it from the factory, order it as an accessory. See the accessory list provided in this manual.

The wall mounting kit consists of the following parts:

- Wall Mount Base Plate
- Wall Mount Clamps

For accessibility of the front panel and recommendations for cooling with the heat pipe, follow these recommendations:

The height of the front panel must be suitable enough for you to have clear visibility and free access of the front panel.

Mount the base plate horizontally so that it ensures that the CIU 888 is also mounted horizontally.

Follow these steps to mount the unit to the Wall Mount Base Plate:

1. Hold the Wall Mount Base Plate against the wall and make a marking for the holes. Drill holes and fix the screws in place.



CAUTION! Ensure that the bracket is perpendicular to the floor and does not tilt sideways.

Mechanical Installation - Mounting

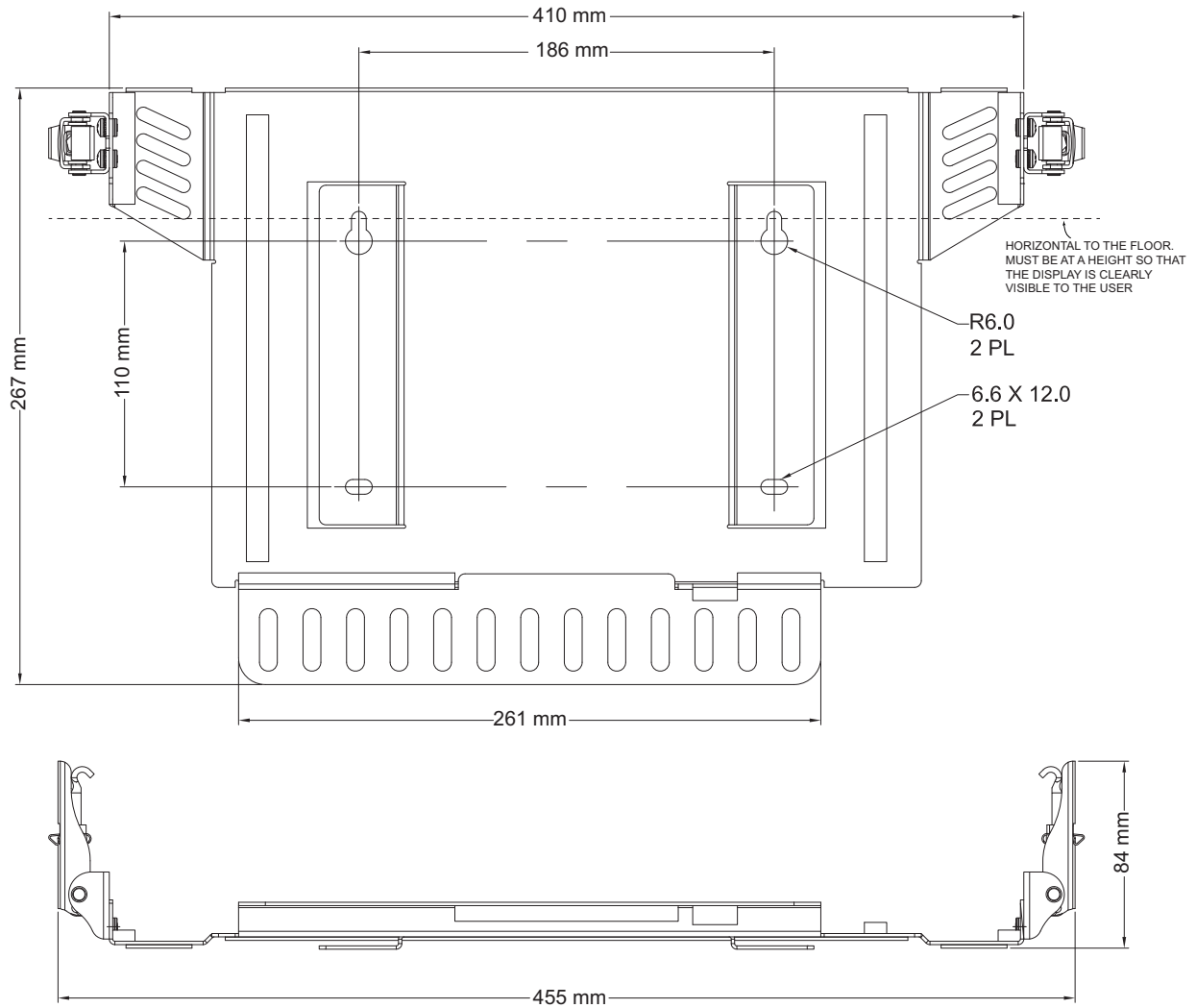

FIGURE 3-6

Marking Key Holes

2. Locate the Wall Mount Base Plate over screws and fasten the screws on top and bottom as illustrated in the following figure.

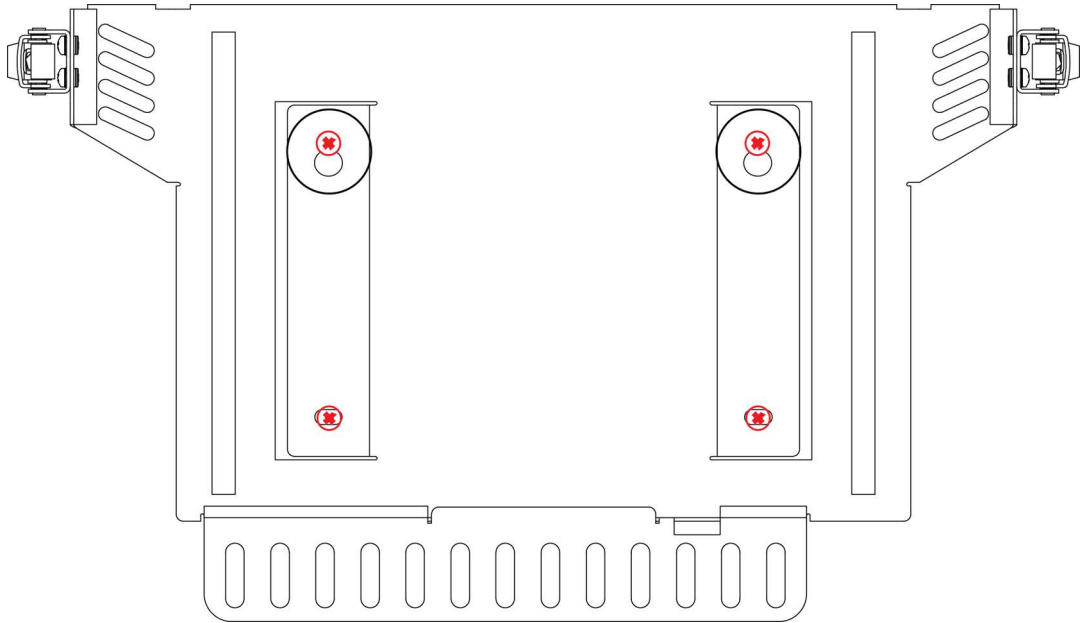

FIGURE 3-7

Installing the Wall Mount Base Plate

3. Mount the unit to the wall mount bracket. First the wall mount base plate assembly is hung on the wall by means of key slot openings. Foam pads are provided on the face and bottom side of the bracket to provide cushioning to the unit.

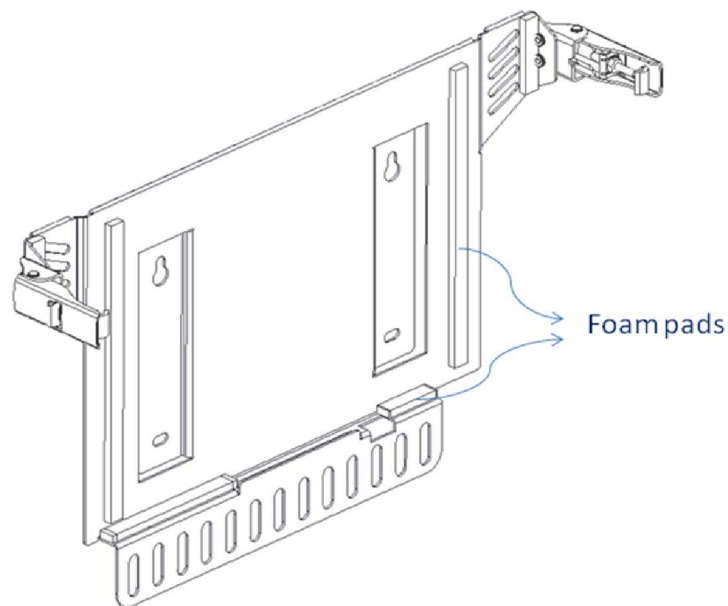

FIGURE 3-8

Mechanical Installation - Mounting

4. Fix the locking plate to the wall mount clamp by means of fasteners.

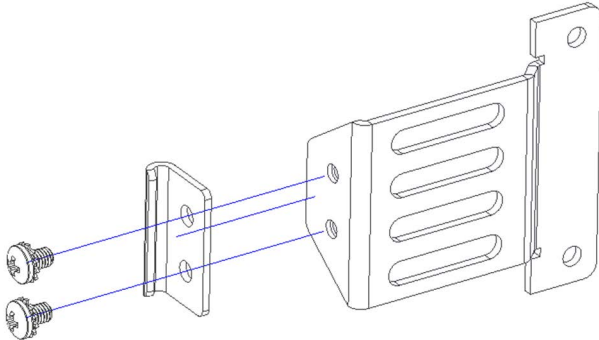

FIGURE 3-9

5. Repeat the process for the other clamp as well.
6. The wall mount clamps are fixed to the base of the unit by means of fasteners on the either sides.

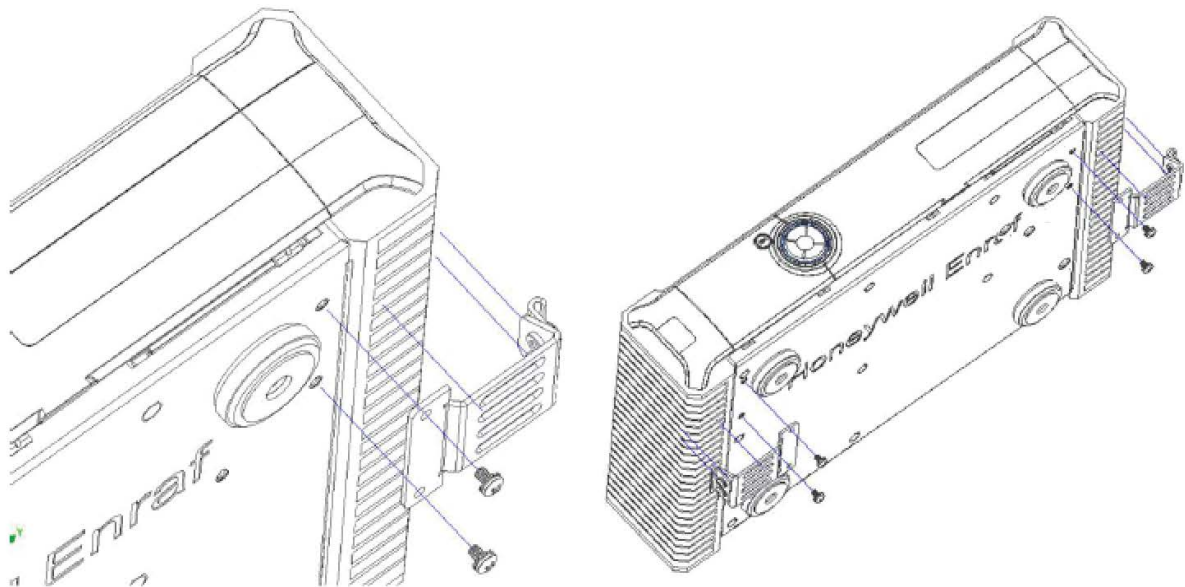

FIGURE 3-10

7. Place the unit on the wall mount plate by supporting it on the base of the plate.

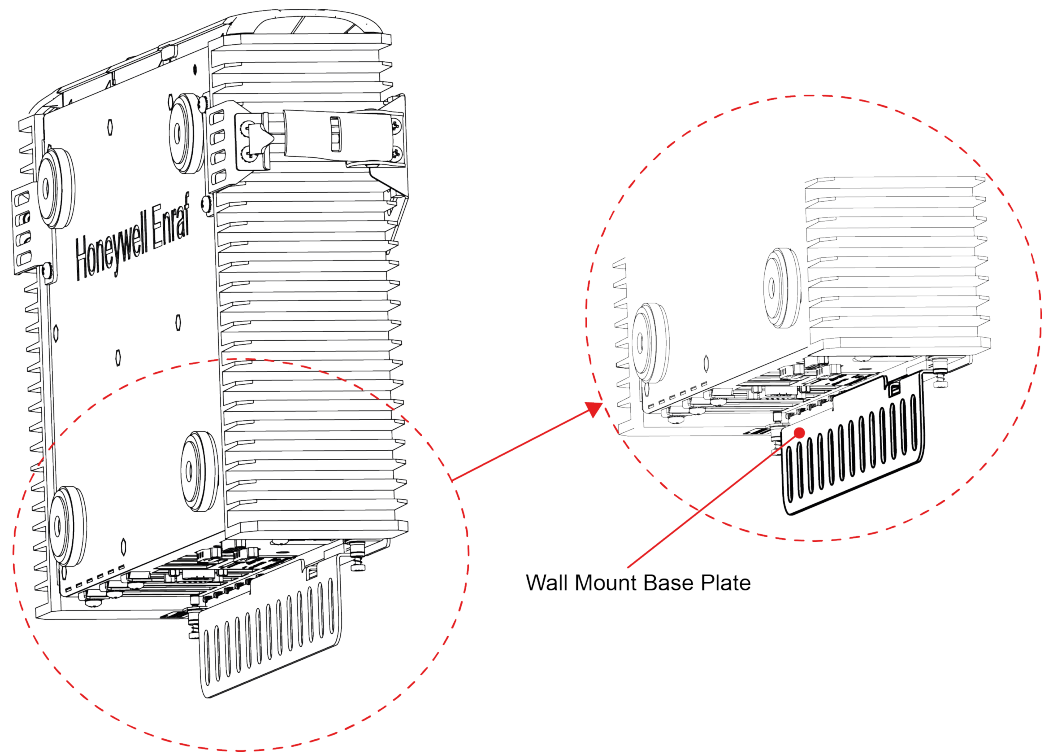

FIGURE 3-11 Unit on the Wall Mount Base Plate

NOTE: Ensure that the top cover is secured behind the tab provided on the base plate so that the unit cannot be removed without lifting it.

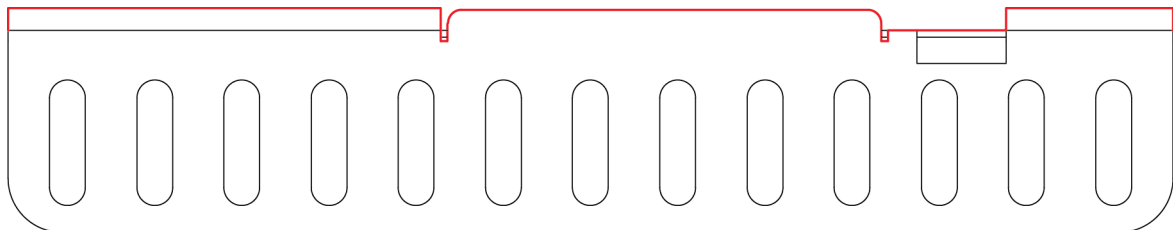

FIGURE 3-12 Unit is placed behind the tab provided on the base plate

Mechanical Installation - Mounting

8. After placing the unit on the Wall Mount Base Plate, engage the hook to the latch keeper.

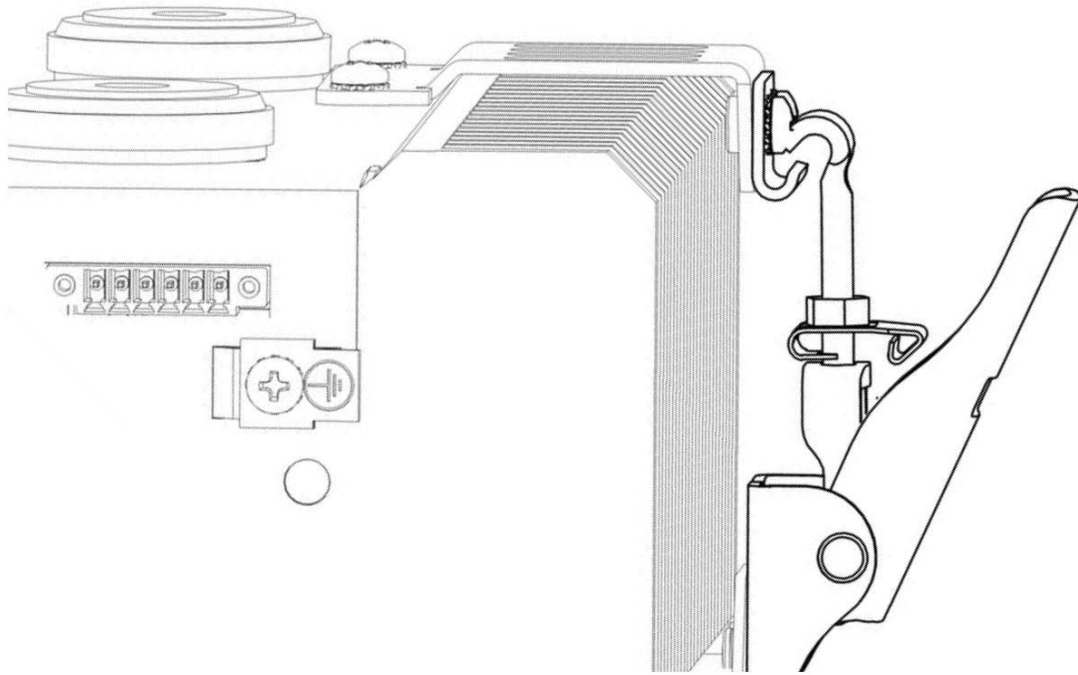

FIGURE 3-13

Latch the Hooks

NOTE: Loosen the nut behind the hook to adjust the height of the hook.

CAUTION! Ensure the hook positions on both sides are maintained at the same length.



Mechanical Installation - Mounting

9. Press the latching clip on both sides, to snap with the hook. Once it is snapped with the clip, the hook is pulled back and the unit is held securely.

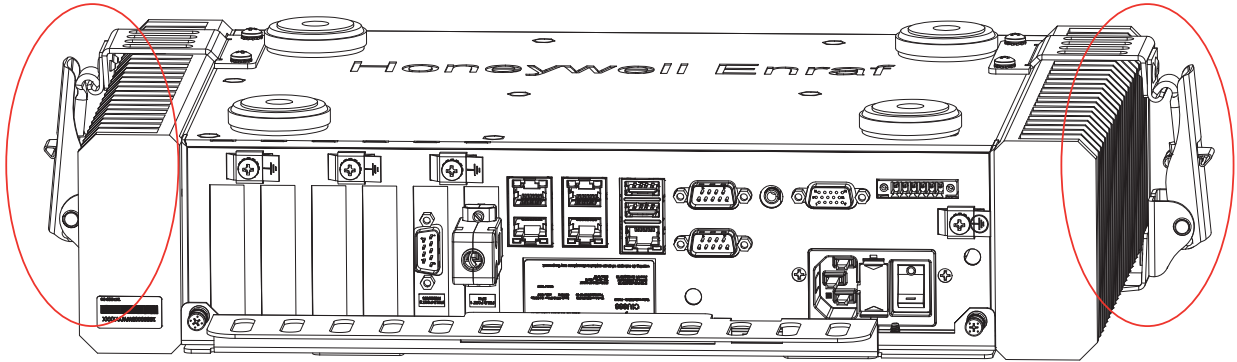

FIGURE 3-14

Securing the Unit

Mechanical Installation - Mounting

10. All the cables terminating on the CIU 888 unit are tied to the mounting bracket using the slots with cable ties as shown in the following figure:

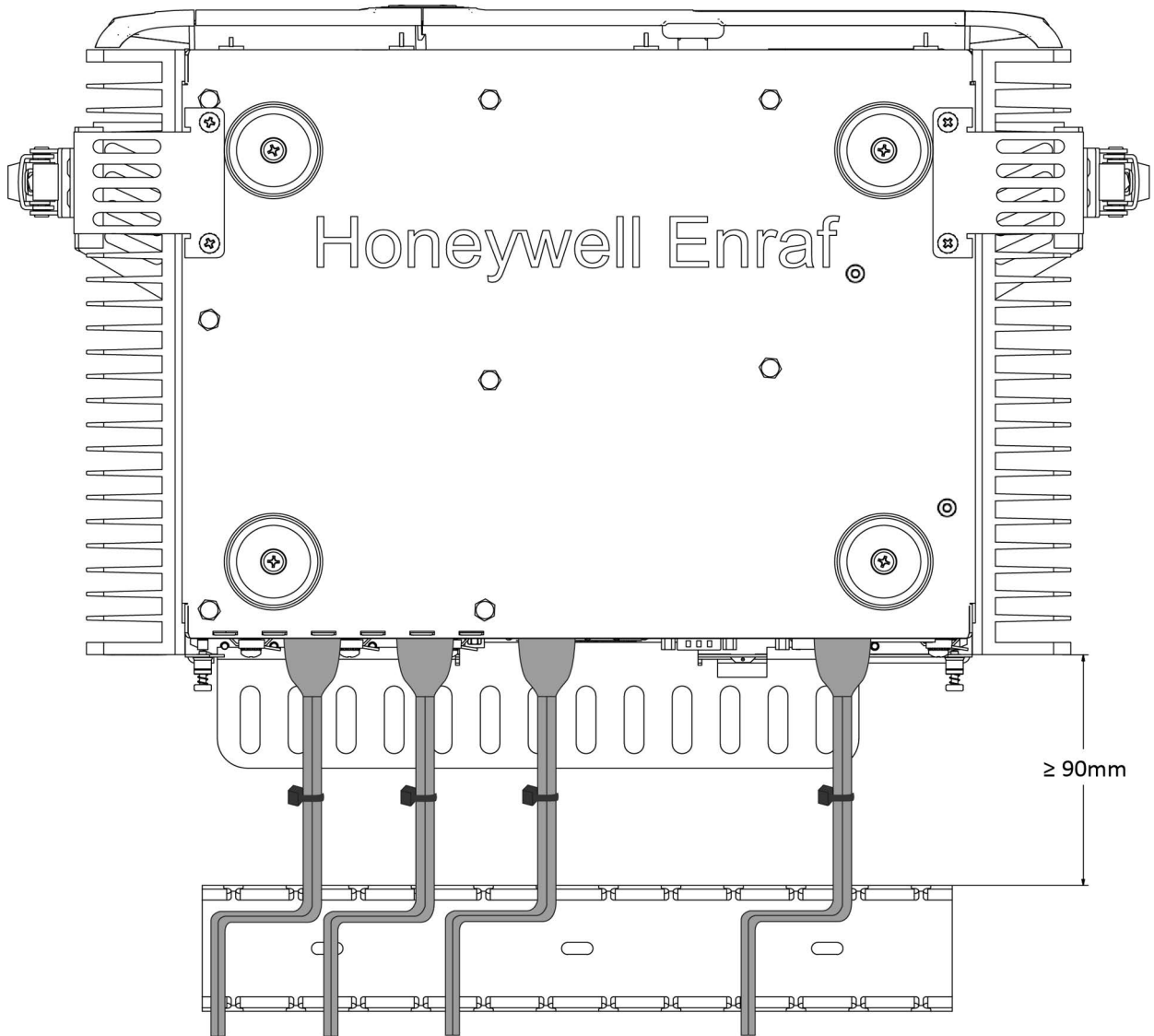

FIGURE 3-15

Cable Tray

This page is intentionally left blank

CHAPTER 4 ELECTRICAL INSTALLATION

4.1 Electrical specification

Electrical specification	
Power Supply	100-240 Vac, auto ranging (-10% to +10%), 45-65 Hz
Power Rating	Max. 60 VA (35 VA nominal)
Nominal Start-Up Current	60 mA (Fuse: 2A Slow Blow) Start Up Current is (inrush): 60 A @230V
Overall Voltage Category	II
Cooling System	2 heat sinks with heat pipe design (no moving parts)
Battery	Type 3V, 225mAh, 23mm (for back-up system clock only - 10 years estimated service time)

4.2 Grounding

CIU 888 is grounded through the earth wire of mains cable and also through dedicated earth terminal (mandatory) provided on the rear side of the CIU 888. There are three more earth terminals provided on the rear side of CIU 888 to connect to earth when bpm communication channels are engaged.

A 4 mm two single or stranded copper wires are generally accepted by the safety authorities.

NOTE: The grounding should be performed in accordance with the local regulations.

4.3 Mains

The mains supply for the CIU 888 is 100-240V_{AC}, 50/60 Hz. The power rating is 60 VA max (35 VA typical). Supply variations of +10% and -10% are allowed. The power supply unit inside the CIU 888 detects to which supply it is connected and automatically switches over to the correct setting.

The mains block contains two fuses one on line and other on neutral (size: Ø5 x 20 mm), both rated: 1.6 A slow blow (T1.6 A L 250 V) in accordance with IEC 60127-2/III.

Fuse Details:

- Part#: 0239002.MXP
- Make: Littelfuse
- Description: FUSE 250 V UL SLOBLO 5X20 MM 2A



CAUTION! Check if the mains supply voltage falls within the specified limits of 100-240 VAC.

CIU 888 has been supplied with a C13 plug (H05VV-F3G0.75 mm²/1 mm²) on the CIU 888 side and open end wires on the Line socket side. You can install country specific plug to these open end wires and use it.

The mains switch is located on the rear side of the CIU 888.

NOTE: Always use the proper installation material. Failure to use the proper material will impact the safety of the equipment.

NOTE: The mains connection terminal and the external ground terminal must be grounded, which are available at the rear side of the CIU 888.

4.4 CIU 888 Interface Summary

CIU 888 Front View

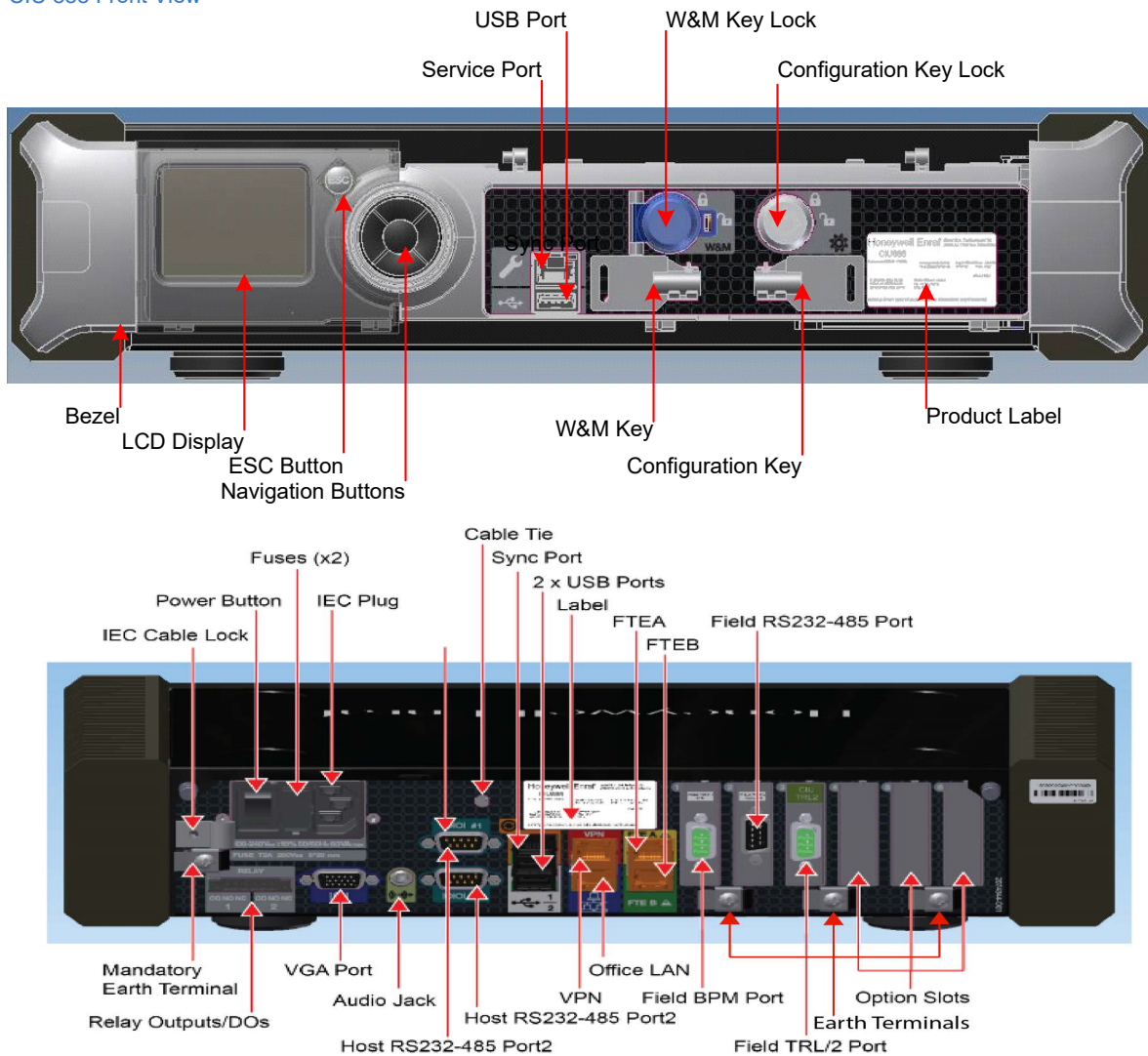

FIGURE 4-1 CIU 888 Interface Summary

NOTE: Earth terminals need to be connected when BPM ports are used.

4.5 Field and Host Port Connections

4.5.1 Enraf Field Bus (BPM Port)

A maximum of 80 gauges can be connected to the CIU 888. Gauges should be divided over the field ports with a recommended maximum of 15 instruments per line. Best results are obtained when the Enraf field bus signal to the gauges is connected in a “star” configuration. See FIGURE 3-2. Enraf Field Bus Board (BPM Board) can be placed in any of the option slots 1 – 6.

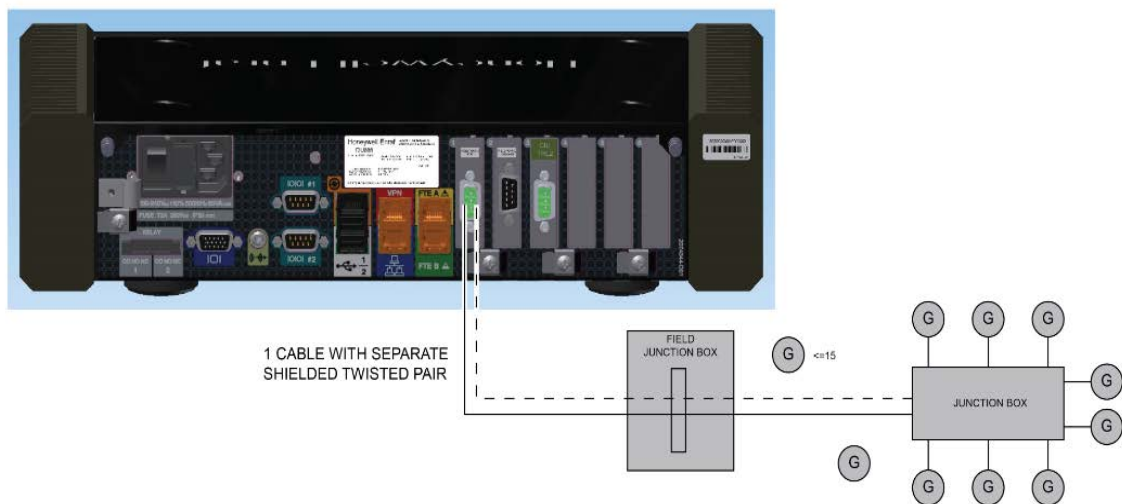

FIGURE 4-2

Enraf Field Bus (BPM Port)

Connect the Enraf Field bus cable to the two outer terminals of the connector at the Field Port. The Enraf field bus signal is not polarity sensitive. The shield (dotted lines) of the Enraf field bus cable must be connected to the centre terminal. See FIGURE 5-3.

See section 4.4 "CIU 888 Interface Summary" for locating the ports.

NOTE: Number of instruments per BPM field line depends on the cable specifications and the total cable length.

Enraf Field Bus Connection:

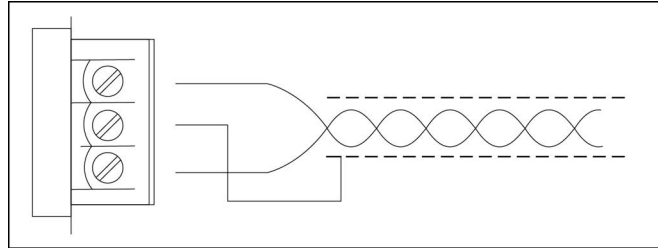

FIGURE 4-3

Enraf Field Bus connection

It is recommended to use the following cable specifications for effective results.

- One twisted and shielded pair cable
- Rmax: 200 Ω (per line)
- Cmax: 1 uF (to each other and to ground)

NOTE: To prevent cross-talk, only individually shielded twisted pairs should be used in a multi-core cable.

4.5.2 TRL/2 Field Bus

A maximum of 48 gauges can be connected to the CIU 888. Gauges should be divided over the field ports with a recommended maximum of 8 instruments per line. Best results are obtained when the TRL/2 field bus signal to the gauges can be connected in a “Multi-drop” configuration. See FIGURE 3-2. TRL/2 Field Bus Board (TRL/2 Board) can be placed in any of the option slots 1 – 6.

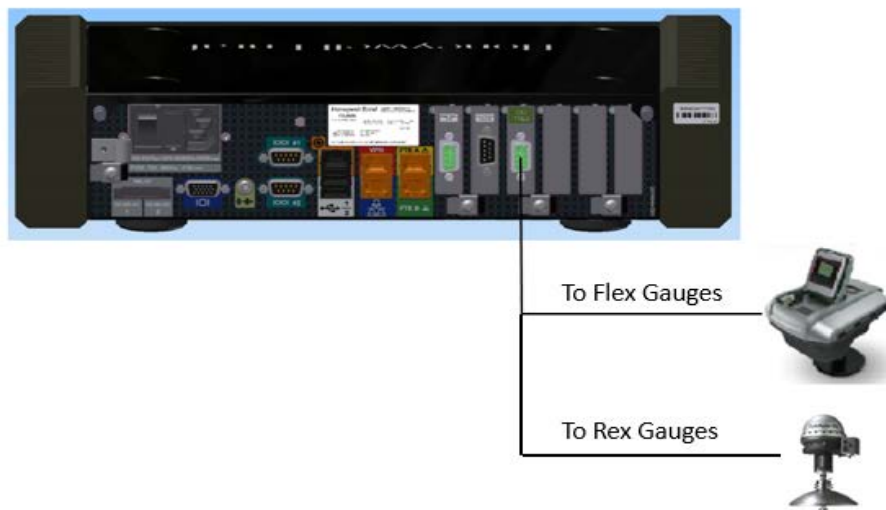

FIGURE 4-4

TRL/2 Field Bus

Connect the TRL/2 Field bus cable to the two outer terminals of the connector at the Field Port. The TRL/2 field bus signal is not polarity sensitive. The shield of the TRL/2 field bus cable must be connected to the centre terminal. See FIGURE 5-3.

See section 4.4 "CIU 888 Interface Summary" for locating the ports.

NOTE: Number of instruments per TRL/2 field line depends on the cable specifications and the total cable length.

TRL/2 Field Bus Connection:

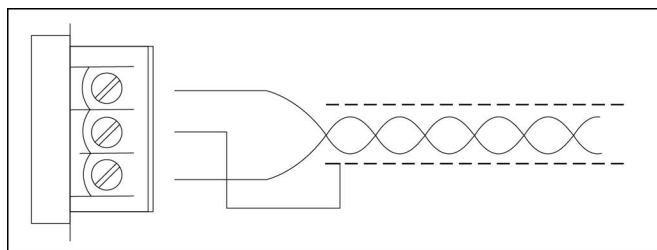

FIGURE 4-5

TRL/2 Field Bus connection

It is recommended to use the following cable specifications for effective results.

- Two conductors, shielded twisted pair
- Cmax: 668 nF (18 AWG); 4 km
- Rmax: 98.4 Ω (22 AWG); 2 km
- Lmax: 1.96 mH (18 AWG); 4 km
- Length (max): 4 km, stub not > 100 m
- Num. of instruments (max): 1 Parent, 8 children
- Gauge (All are shielded twisted pair):
 - Belden 88760 (18 AWG) 4 km
 - Belden 8762 (20 AWG) 3 km
 - Belden 88761 (22 AWG) 2 km
 - Belden 88641 (24 AWG) 1 km
 - Stub not > 100 meters
- No of strands: 7 or 19 (or more, higher => better performance)
- Shielded connection: Earthed towards Host system (FCU/FBM)

4.5.3 Field RS232-485 Port

A RS232-485 Field Board for connection to a CIU 888 (Communications Interface Unit) can be placed in any of the option slots 1 to 6. These ports have galvanic isolation.

See the section 4.4 "CIU 888 Interface Summary" for locating the ports.

4.5.3.1 Field RS232-485 Port in RS232C mode [Part of a future release]

See FIGURE 4-6 for RS-232C pin configuration and connections.

Cable requirements for RS232 connections:

- Max. length: 15 m (50 ft)
- Overall shielded

Connections over short distances can be made with a “null modem” cable. If the distance is longer than 15 m (50 ft), a modem connection must be used. The connection to the modem depends on the type of modem used.

Pin layout for 9 and 25 pins D-type connector

Signal Name	Pin no.	
	9 Pins	25 Pins
Protective ground	Chassis	1
DCD	1	8
RXD	2	3
TXD	3	2
DTR	4	20
Signal ground	5	7
DSR	6	6
RTS	7	4
CTS	8	5

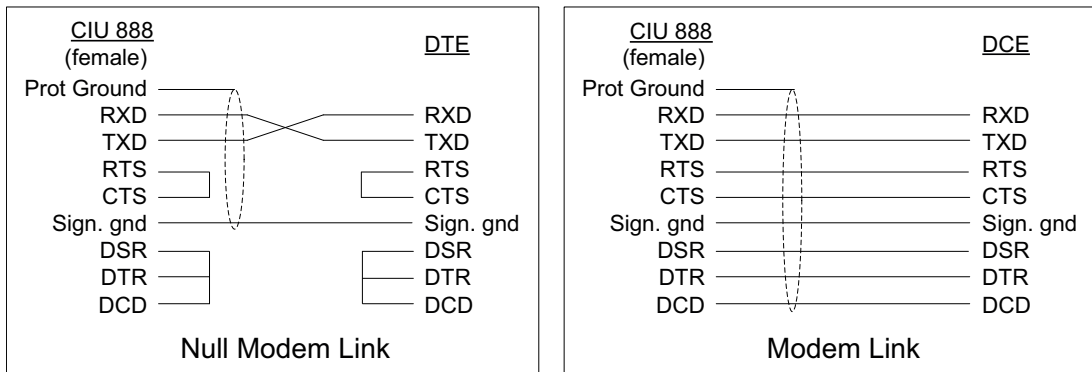

FIGURE 4-6 Field RS232C Port Connection Details

4.5.3.2 Field RS232-485 Port in RS485 mode

See FIGURE 4-7 for RS-485 pin configurations and connections.

Cable requirements for RS-485 connection:

- Max. length: 1000 m (3000 ft)
- Minimum one twisted pair (typical: 50 twists per metre) with a ground wire
- Overall shielded
- Rmax:0.12 Ω /m (per line)
- Cmax:119 pF/m
- Lmax:1.45 mH/m

See FIGURE 4-7 (A) for full duplex RS-485 connection or FIGURE 4-7 (B) when a half duplex RS-485 connection is required. For half-duplex connect signals RXA with TXA and RXB with TXB inside the cable connectors. Place 120 Ω resistors at the receive terminals in the cable connectors.

Direct connection can only be made if the CIU 888 and the DTE (CIU 888 or host computer system) are grounded at the same point.

In all other cases, ensure there is at least a proper galvanic isolation at the DTE side. Galvanic isolation can also be obtained by means of a modem connection between the CIU 888 and the host computer system.

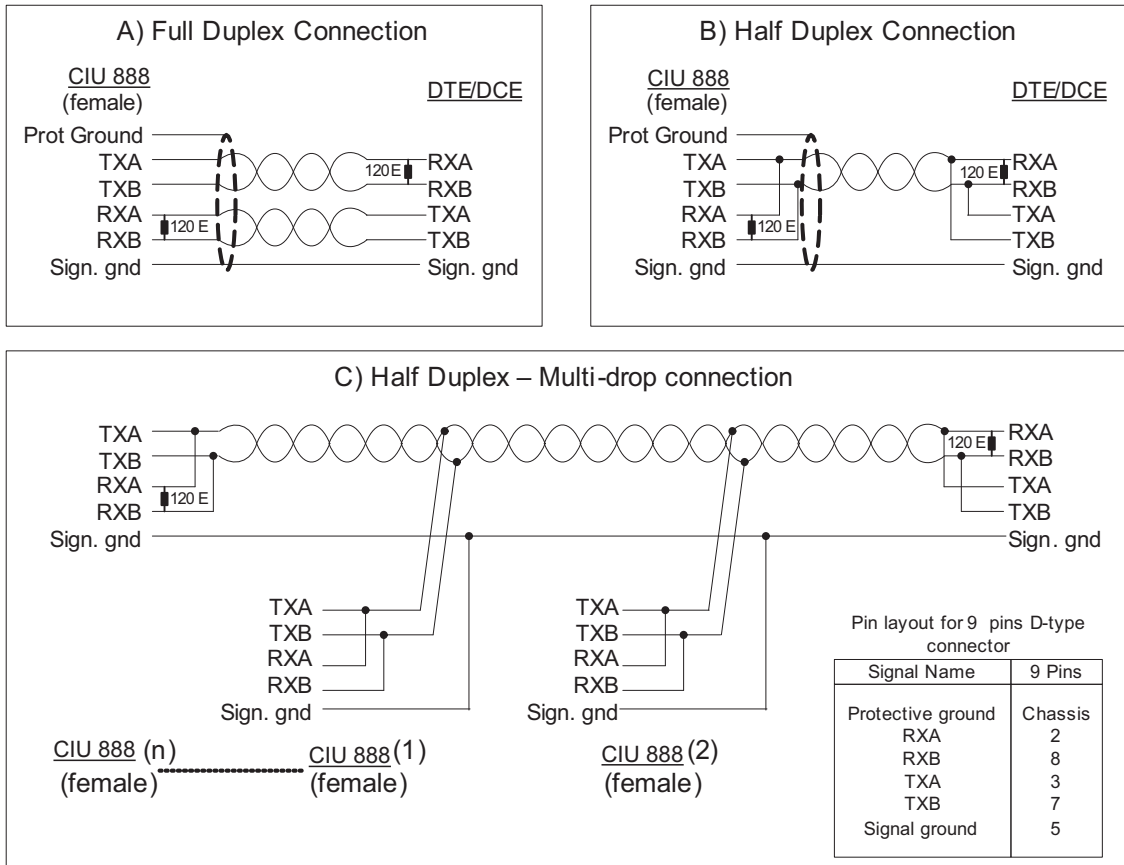

FIGURE 4-7

Field RS485 Port Connection Details

4.6 Host RS232-485 Ports (MODBUS Output)

The Host Ports (MODBUS Host Ports) can be found on the rear of the CIU 888 and these can be configured for either RS-232C or RS-485.

See the sections 4.5.3.1 "Field RS232-485 Port in RS232C mode [Part of a future release]" and 4.5.3.2 "Field RS232-485 Port in RS485 mode" for more information regarding the field ports RS-232C and RS-485.

Also, see the section 4.4 "CIU 888 Interface Summary" for locating the ports.



CAUTION! *The optional ports are galvanically isolated and the fixed Host Ports have basic isolation.*

4.7 Ethernet Ports

CIU 888 has 6 Ethernet ports, one on front side and 5 on rear side of CIU 888. All ports are 10/100 Mbps compliant and support Auto MDIX support (auto detects Straight or Cross cable and switches accordingly). See the section 4.4 "CIU 888 Interface Summary" for locating the ports.

Front Side Port:

Service Port - This port is used for debugging and diagnostic purposes.

Rear Side Ports:

Sync Port - This port is required in a redundancy setup and is used to sync between two CIU 888s (primary and secondary)

Office LAN - This port is used to connect to Office LAN

VPN Port - This port supports secure remote access. [Part of a future release]

FTEA and FTEB Ports - Fault Tolerant Ethernet ports.

Ethernet Cable Specification:

- Cable Type: CAT5
- Frequency: 100 MHz
- Characteristic Impedance: 100 Ω +/-15%

4.8 USB Ports

CIU 888 has 3 USB ports, one on the front side and two on the rear side. Back ports are designed to interface with keyboard and mouse. These are low power devices and require currents less than 100 mA for normal operation. The USB port in the front is intended for USB storage devices and might demand higher current limit. See the section 4.4 "CIU 888 Interface Summary" for locating the ports.

- Back Two Ports Current Limit: 200 mA [Part of a future release]
- Front One Port Current Limit: 500 mA

4.9 VGA Port (Optional Interface) [Part of a future release]

CIU 888 has a standard VGA port to connect to a VGA monitor. The maximum resolution supported is 1920x1200. See the section 4.4 "CIU 888 Interface Summary" for locating this connector.

4.10 Audio Port [Part of a future release]

CIU 888 has a 3.5 mm Audio port to connect an amplifier for alarm announcements. The port can support 32 Ω headphone or 10K Ω nominal pre-amplifier load. See the section 4.4 "CIU 888 Interface Summary" for locating the ports.

4.11 Audio Plug and Signal Details [Part of a future release]

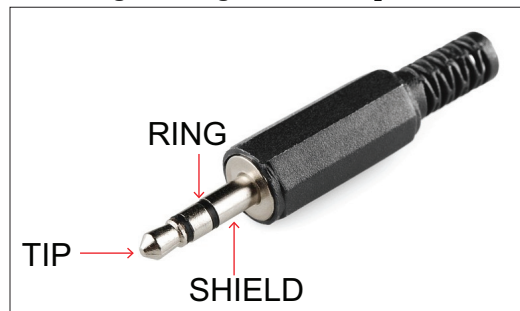

FIGURE 4-8

Audio Plug Details

Following is information in detail regarding FIGURE 4-8.

- Tip: Left
- Ring: Right
- Shield: Signal Ground

4.12 Relay or DO Outputs [Part of a future release]

CIU 888 has two relay outputs. They are also called digital outputs (as they offer make or break connections). See port details chapter for locating this connector.

4.12.1 Relay Contact Specification [Part of a future release]

- DPDT Type Relay
- Rated DC Switching Voltage: 30VDC
- Rated DC Current: 1A
- Minimum Switching Operations: 50000

4.12.2 Relay Layout

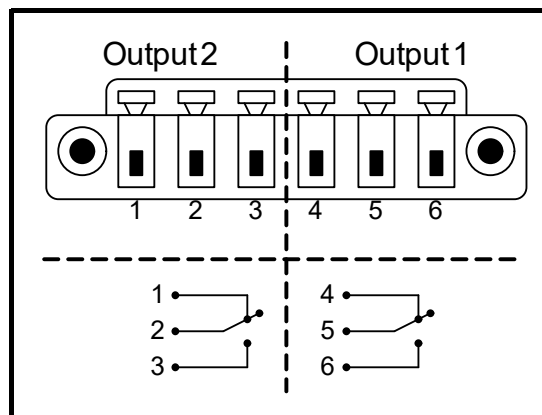
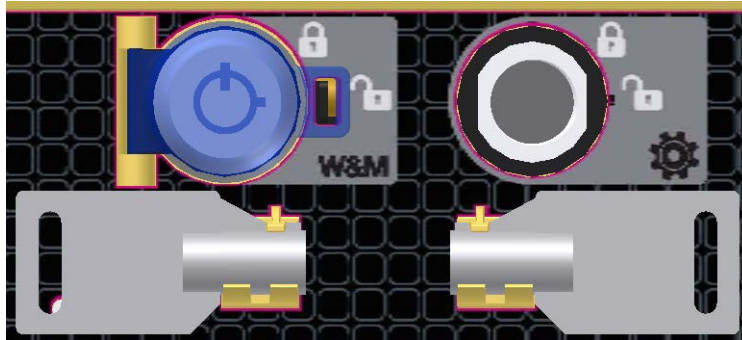

FIGURE 4-9

Relay Layout

4.13 Key Locks

CIU 888 has two key locks. One key lock for W&M and another for Configuration purposes. Lock and unlock positions are shown below. Key pull is possible in both positions.



Spare keys for both keys are available and are supplied with the unit. Store the spare keys in a secure location.

FIGURE 4-10

W&M and Configuration Key Locks

4.14 User Interface

LCD, Navigation Key & Ring of Light

CIU 888 on its front bezel has an LCD module and Key pad for user interface and configuration. A Ring of light to display status.



FIGURE 4-11

User Interface Details

4.14.1 LCD and Navigation Key

Front Bezel has an LCD with 240 x 320 color pixels. This LCD is used as the local HMI for CIU 888. It also has four navigation keys with one “OK” button in center and also a separate “Esc” (Escape) button to operate the screens on LCD.

4.14.2 Ring of Light

CIU 888 has “Ring of Light” to display operation status. This ring of light is constructed with RGB LEDs.

As a part of a future release, CIU 888 will be designed to display NAMUR colors (Green, Blue, Yellow, Orange, and Red) along with a few patterns like Standstill, Blink, Snooze, and Clockwise rotation.

NOTE: Upon power ON the Ring of light displays “Blue” colour in standstill.

CHAPTER 5 APPENDIX A: LIST OF SPARES AND ACCESSORIES

5.1 List of Spares and Accessories

Level	Material	Material Description	Base Unit of Measure	Material Quantity
1	A0888903	Mounting Plate for Wall mount positioning		
2	0187473	ENCLOSURE, WALL MOUNT CLAMP	EA	2
2	0187474	ENCLOSURE, WALL MOUNT BASE PLATE	EA	1
2	2146979	SCREW PH PAN, LOCKWASHER, M4x6mm	EA	4
1	A0888904	Mounting ears for 19" positioning		
2	0187471	ENCLOSURE, MOUNTING BRACKET, RIGHT	EA	1
2	0187472	ENCLOSURE, MOUNTING BRACKET, LEFT	EA	1
2	2146979	SCREW PH PAN, LOCKWASHER, M4x6mm	EA	4
1	A0888911	SET ETHERNET CABLES		
2	4217063	ETHERNET CABLE 1M ORANGE	EA	1
2	4217065	ETHERNET CABLE 3M YELLOW	EA	1
2	4217064	ETHERNET CABLE 3M GREEN	EA	1
2	4217066	ETHERNET CABLE 2M BLUE	EA	1
2	4217067	ETHERNET CABLE 3M RED	EA	1
2	4217068	ETHERNET CABLE 3M GREY	EA	1
1		Cable Mount Accessories		
2	6759081	CABLE CLAMP	EA	1
1	A0888903	Mounting Plate for Wall mount positioning		

TABLE 5-1 List of Spares

Appendix A: List of Spares and Accessories

Level	Material	Material Description	Base Unit of Measure	Material Quantity
1	S0888104	CIU 888 BPM Field Board		
2	0888104	ASSEMBLY, BPM FIELD CARD MODULE	EA	1
1	S0888103	CIU 888 LCD BOARD		
2	0888103	ASSEMBLY, LCD PCB	EA	1
1	S0888105	CIU 888 RS232/485 Field BOARD		
2	0888105	ASSEMBLY, RS232/485 FIELD CARD MODULE	EA	1
1	S0888108	CIU 888 TRL2 SPARE FIELD BOARD		1
1	S0888605	CIU 888 BATTERY PIGGYBACK BOARD-PWA		
2	0888605	PIGGY BACK PCB	EA	1
2	2695199	PCB SUPPORT LOCKING TEARDROP 7/16"	EA	1
1	S0888902	CIU 888 SET OF 2 KEYLOCKS		
2	0888501	CABLE ASSY, KEYLOCK SWITCH, W&M	EA	1
2	0888504	CABLE ASSY, KEYLOCK SWITCH, CONFIGURATION	EA	1
1	S0888905	FUSE 250V UL SLOBLO 5X20MM 2A		
2	2656018	FUSE DRWR FOR PWR MOD F'GRIP 2PL	EA	1
2	2655084	FUSE 250V UL SLOBLO 5x20MM 2A	EA	2
1	S0888906	COMPACT FLASH, 4G		
2	2849906	COMPACT FLASH, 4G	EA	1
1	S0888907	CIU 888 POWER SUPPLY + THERMAL PAD		
2	3862297	AC-DC POWER SUPPLY 75W 12VDC	EA	1
2	6406013	SCREW PAN PH, M3x5mm	EA	4
2	6476503	CIRCLIP, M3SS DIN125A-A2	EA	4
2	0187509	THERMAL PAD 195.0x33.0x1.0mm	EA	1

TABLE 5-2

List of Accessories

For service-related questions, contact:

Technical Assistance Centre

Phone:

+1 800 423 9883 or

+1 215 641 3610

E-mail:

HFS-TAC-SUPPORT@honeywell.com

Copyright © 2022 - Honeywell

All rights reserved. No part of this manual may be reproduced in any form, by print, photoprint, microfilm or any other means without the written permission from Honeywell.

For More Information

To learn more about Honeywell Enraf's solutions, contact your Honeywell Enraf account manager or visit www.honeywellenraf.com.

Americas

Honeywell Enraf Americas, Inc.
1250 West Sam Houston Pkwy S.
Houston, TX 77042
USA
Phone: +1 (480) 293-2042
Email: enraf-us@honeywell.com

Asia Pacific

Honeywell Pte Ltd.
17 Changi Business Park Central 1
Singapore 486073
Phone: +65 6355 2828
Email: enraf-sg@honeywell.com

Europe, Middle East and Africa

Honeywell Enraf
Delftechpark 39
2628 XJ Delft the Netherlands
Phone: +31 (0)15 2701 100
Email: enraf-nl@honeywell.com

4417590_Rev16
December 2022
© 2022 Honeywell.

The Honeywell logo is displayed in a bold, red, sans-serif font.