



DISPENSERS



FUEL KITS



PUMPS



METERS



NOZZLE



FILTRATION

# EX80

## FEATURES

- 30 MIN. DUTY CYCLE ON/OFF
- THERMAL PROTECTION
- SUCTION UNIT WITH INTEGRATED FILTER
- HIGH FLOW RATE
- UNDER UL TESTING

The EX80 is the first addition to the new line of heavy duty AC fuel pumps by PIUSI. Capable of a 20 GPM flow rate at-the-nozzle, the EX80 has a duty cycle of 30 minutes on and 30 minutes off.

## PERFORMANCE

UP TO

**20 GPM**

FLOW RATE

**AC**  
**VOLTAGE**

POWER

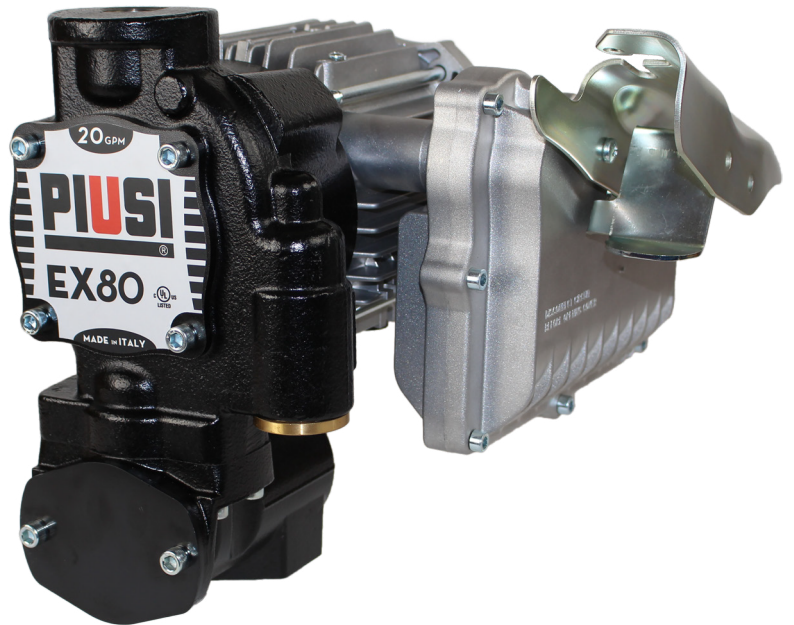

EX80



## PACKAGING

PART #	WEIGHT		PACKAGING		
	KG	LBS	MM	INCH	PCS/BOX
FO0391500	25	55	240X400X390	10X16X15	1



FLUID  
MONITORING

# PIUSI



AIR



ANTIFREEZE



DEF



BIODIESEL



DIESEL



FOOD



GASOLINE



GREASE



KEROSENE



OIL



WATER



WINDSCREEN

## CHART

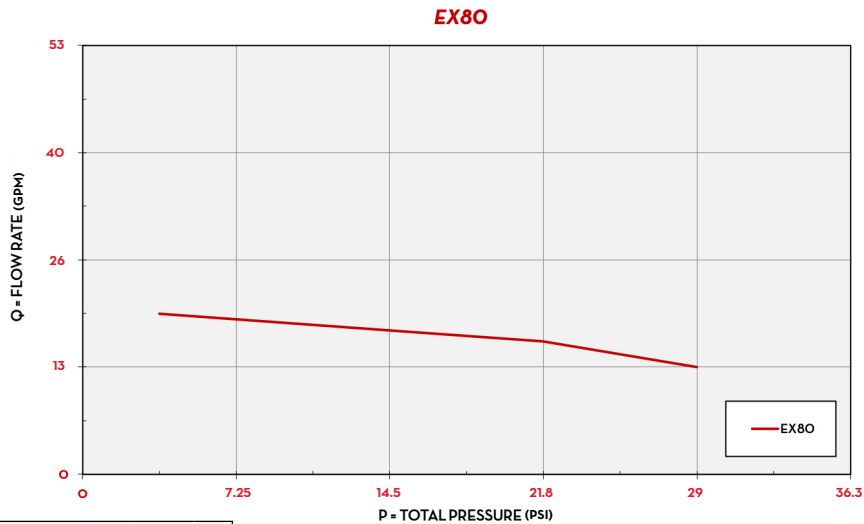

TYPE OF FLUID DIESEL

TEMPERATURE 68 °F

## IN THE BOX

- EX80 / EX100 / EX140 PUMPS
- NOZZLE HOLDER
- 1" 1/4 CONNECTOR
- 90° ELBOW
- INSTRUCTION MANUAL

## DETAILS



MESH STRAINER



1" 1/4 CONNECTOR



90° ELBOW

## DIMENSIONS

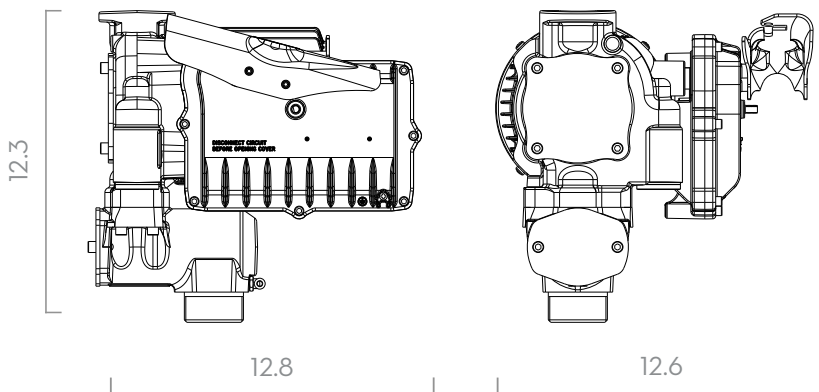

Dimensions expressed in inches

## MATERIALS

- BODY: CAST IRON
- ROTOR: SINTERED STEEL
- VANES: TECHNOPYLIMER
- SEAL: VITON
- SHAFT: STEEL

A 1" LINE MUST BE USED FOR THE EX80. THIS INCLUDES ALL ACCESSORIES SUCH AS HOSE, FITTINGS, METERS, NOZZLES, ETC.

## TECHNICAL DATA

PART #	DESCRIPTION	FLUIDS TYPE	FLOW RATE		VOLTAGE			DUTY CYCLE		RPM	INLET		OUTLET	
			L/MIN	GPM	AC V./HZ	DC VOLT	POWER WATT	AMP. MAX.	MINUTES		NPT	NPT		
FO0391500	EX80 20GPM 120V (PUMP ONLY) 30 MIN DUTY	<b>D</b> <b>K</b>	75	20	120/60		780	6.5	30 ON/OFF	1450	1" 1/4		1"	

(\*) UPON REQUEST IT IS AVAILABLE WITH DIFFERENT VOLTAGES AND 60 HZ FREQUENCY. IT IS RECOMMENDED THAT A 1" LINE BE USED FOR HIGH FLOW PUMPS. THIS INCLUDES ALL ACCESSORIES SUCH AS HOSE, FITTINGS, METERS, NOZZLES, ETC.

# EX80

UL