

94140 Spring Loaded Pressure Relief Vent

The Shand & Jurs Model 94140 Spring Loaded Pressure Relief Vent reduces excessive venting of product in liquid storage tanks. Available for open or closed vent systems, this vent provides pressure relief by either venting vapor into the atmosphere or piping emissions in a closed loop system.

Available in 2"- 12" sizes, this vent is all weather for all materials and services. Higher pressure settings are accommodated using a unique method of spring loading which ensures highly reliable operation and reduces excessive venting of product at a relatively low cost. Pressure settings range from 1 psig through 15 psig for all sizes except 12" which has a maximum of 12 psig. Flange connections match ANSI 150 lb. raised face or flat face for cast iron, steel and stainless steel construction. Aluminum construction comes in ANSI 125 lb. flat face flange only.

Standard materials offered are aluminum, cast iron, cast steel and 316 stainless steel. Standard seats are aluminum and 316 stainless steel.

The pallet to seat diaphragm is air cushion seated FEP for long service life and optimum reliability. This diaphragm helps to ensure a high resistance to any ice and gum formations, prevents the pallet from sticking to the seat. The carefully engineered body, seat and pallet offers a superior combination of tight sealing and high capacity at lower over-pressure.

An Expanda-Seal is available on the pressure pallet to assure minimal leakage up to 95% of set pressure.

One of the most important features which should be noted in the Model 94140 design is the variety of construction materials available. A wide range of highly corrosive and toxic products common to the petroleum, petro-chemical and chemical industries, require that a pressure vent be able to withstand this environment and still function reliably. For few instances where our standard materials may not be suitable, optional materials are readily available.



Features

- Aluminum, cast iron, steel or stainless steel
- Pressure range between 1 and 15 PSIG, 12 PSIG Max. for 12" size
- All-Weather Teflon Coating available
- Guided pressure pallet assures smooth lift and closure
- Unique diaphragm construction assures positive seal and minimal blowdown
- Easy inspection of internal components
- Withstands variety of materials including highly corrosive and toxic products
- Pallet lip design contributes to high flow characteristics

94140

Spring Loaded Pressure Relief Vent



Specifications

Standard Pressure Setting Range:

1-15 psig for 2"-10" sizes
1-12 psig for 12" size

Flanges:

Matches valve size 150 lb. ANSI compatible.
EN1092-1 and JIS 10K sizes available.
Aluminum available in Flat Face only.

Temperature Range:

Process Temperature ranges for body material:
-65°F to 250°F (Aluminum)
-65°F to 350°F (316 Stainless Steel)
-20°F to 350°F (Carbon Steel)
-20°F to 325°F (Iron)

Materials of Construction

Body:

Aluminum, Iron, Steel or 316 Stainless Steel available

Seat:

Aluminum or 316 Stainless Steel

Hood:

Stainless Steel for 2", 3", 4", 6" & 8"
Aluminum for 10" & 12"

Diaphragm:

FEP (Fluorinated Ethylene Propylene), FKM (Fluoroelastomer),
NBR (Nitrile-Butadiene), PFA (Fluoroplastic Film)

Closed Vent Outline Dimensions

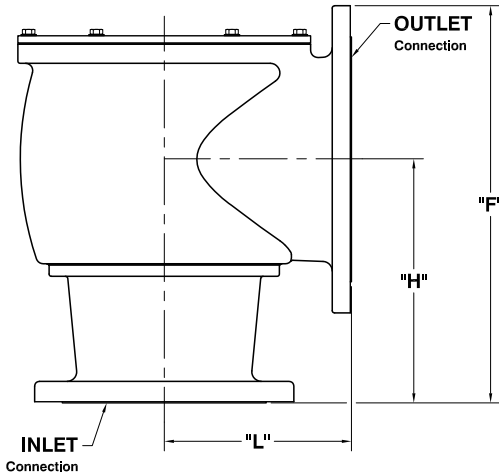

Vent Size*	"F"	"H"	"L"
2" x 2"	8	5	4 1/4
2" x 3"	10 3/8	5	4 1/4
3" x 3"	9 5/16	5 9/16	5 1/4
3" x 4"	12 1/8	5 15/16	5 1/4
4" x 4"	11 1/2	7	6 1/2
4" x 6"	14 1/8	7	5 15/16
6" x 6"	14 7/8	9 3/8	8 3/8
6" x 8"	17 1/4	10 5/16	8 1/4
8" x 8"	18 7/16	11 1/16	9 3/4
8" x 10"	20 7/8	12 1/16	9 3/4
10" x 10"	21 7/8	13 7/8	11 19/32
10" x 12"	24 5/8	14 7/8	11 19/32
12" x 12"	25 3/4	16 1/4	12 13/16
12" x 14"	27 5/8	16 7/8	12 13/16

Tolerances: ± 1/16

Open Vent Outline Dimensions

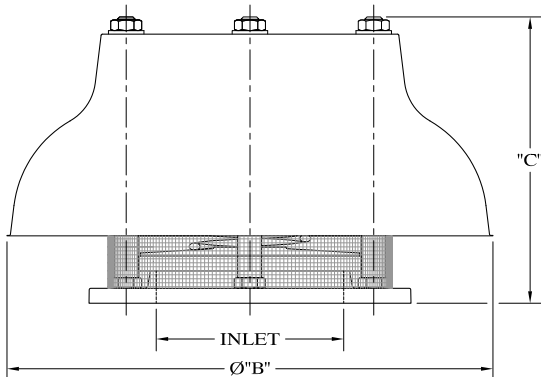

Vent Size	"Ø B"	"C"
2"	12 7/8	7 5/8
3"	13 9/16	7 7/8
4"	15 15/16	9 1/8
6"	18 5/8	9 1/8
8"	18 5/8	12 1/8
10"	25 9/16	16 1/2
12"	29 7/8	19 5/8

Tolerances: ± 1/16

All designs subject to change. Certified dimensions and specifications available upon request.



5911 Butterfield Road Hillside, IL 60162 • tel: (708) 236-6000 • fax: (708) 236-6006
sales@ljtechnologies.com • www.ljtechnologies.com • ISO 9001: 2015 Certified

Rev: 94140-3G

94140 Ordering Guide

Model Number Selection

The model number will consist of a base number **94140** followed by 8 digit numbers. These digits will represent 5 option tables.

94140 - AB - CD - EF - GH

Ordering Information

Specify:

1. Model 94140 Spring Loaded Pressure Only Relief Vent
2. Size, Body Material, and Service
3. Type of Vent
4. Pressure Setting and process Temperature
5. Seal Type
6. To Specify CE for Ordinary EU Locations use Table G2
7. ATEX Certification for Group IIB, IIA EU Locations, use Table G1



Table AB - Size, Material, Configuration & Flange

Option A	Materials: Body, Trim	Vent Type	CV Type
1	Aluminum, SS	Open, FF	-
2	Aluminum, SS	Closed, FF	Outlet > Inlet
4	Cast Iron, SS	Closed, FF	Outlet > Inlet
5	Cast Iron, SS	Closed, RF	Outlet > Inlet
6	Steel, SS	Closed, FF	Outlet > Inlet
7	Steel, SS	Closed, RF	Outlet > Inlet
8	316 SS, 316 SS	Closed, FF	Outlet > Inlet
9	316 SS, 316 SS	Closed, RF	Outlet > Inlet
B	Steel, SS	Open, FF	-
C	Steel, SS	Open, RF	-
D	316 SS, 316 SS	Open, FF	-
E	316 SS, 316 SS	Open, RF	-
F	Aluminum, SS	Closed, FF	Outlet = Inlet
G	Cast Iron, SS	Closed, FF	Outlet = Inlet
H	Cast Iron, SS	Closed, RF	Outlet = Inlet
I	Steel, SS	Closed, FF	Outlet = Inlet
J	Steel, SS	Closed, RF	Outlet = Inlet
K	316 SS, 316 SS	Closed, FF	Outlet = Inlet
L	316 SS, 316 SS	Closed, RF	Outlet = Inlet

Option B	Size
2	2"
4	3"
5	4"
6	6"
7	8"
8	10"
9	12"

Trim includes: Stem, Stem Guide, Side Guides, Nuts, Bolts, Screen.

SS - Stainless Steel

302 SS Spring as Standard (Other material available depending on set point 316 SS (lower SP) or 17-7PH (higher SP)).

Table CD - Pressure Setting Ranges (PSIG)

Option CD	Range From	Range To
01	1.0	2.0
02	2.1	3.0
03	3.1	4.0
04	4.1	5.0
05	5.1	6.0
06	6.1	7.0
07	7.1	8.0
08	8.1	9.0
09	9.1	10.0
10	10.1	11.0
11	11.1	12.0
12	12.1	13.0
13	13.1	14.0
14	14.1	15.0

ATEX and CE Models are Limited to Options 01-06.

12" Size Maximum Set Point 12 PSIG

Table EF - Flange Type & Seal Material

Option EF	Description
0X	ANSI 125/150lb. FF
1X	ANSI 125/150lb. RF*
2X	EN1092-1 PN 16 FF
3X	EN1092-1 PN 16 RF*
4X	JIS 10K FF
5X	JIS 10K RF*
X0	FEP
X1	PFA
X2	NBR
X3	FKM

* RF Not Available in Aluminum

Note: Raised faced flanges with smooth finish are standard.
For optional serrated raised faced flanges, consult factory.

Table GH - Seal Type & Trim

Option GH	Description
00	Standard / SS
01	Expand-Seal / SS
*10	ATEX Certified / 316 SS
*11	ATEX Certified Expand-Seal / 316 SS
20	CE Standard Seal / SS
21	CE Expand-Seal / SS
**30	Standard / 316 SS
**31	Expand-Seal / 316 SS

* Pallet, Side Guides, Nuts, Bolts, Screen and Spring are 316 Stainless Steel (ATEX Only - Max. Set Pressure 7 PSIG).

**Pallet, Side Guides, Nuts, Bolts, Screen and Spring are 316 SS

Temperature Limits

Diaphragm Material	Temperature Range
FEP	-65°F to 400°F
FKM	-15°F to 400°F
NBR	-40°F to 250°F
PFA	-65°F to 500°F