



# ScuL-Sense™ Five-Wire Optic Sensor

Liquid Level Sensor for Tank Truck Overfill Prevention

Featuring Dynacheck® – Automatic and Continuous Self-Checking Circuitry



## 5-Wire Sensor

The ScuL-Sense™ design is API compliant and withstands temperature related stresses, dramatically improving reliability across a wide operating range.

## DESCRIPTION

Scully five-wire optic sensors are purpose-built for liquid petroleum product overfill prevention and point level detection.

They are designed to be used with the Scully Intellitrol® and ST-35 series loading rack control monitors. The sensors can also be used with the Scully IntelliCheck® II Monitor or Scully Load Anywhere® Truck Monitor. There is no waiting for the control monitors' permit light to go on because the sensor requires no warm up time. Overfill prevention applications include road tankers, rail cars and storage tanks.

The five-wire optic sensor is a critical component in Scully's unique and patented Dynacheck circuit design. When used in conjunction with Scully electronic monitoring equipment, our overfill protection sensor will provide consistent failsafe monitoring. By constantly checking a "closed loop" pulsing signal across the entire system, Scully ensures a safe and reliable loading operation. If rising fuel contacts the sensor, this signal is interrupted and the controlling pumps and valves are shutdown. No operator involvement is needed to end the loading operation.

## Principle of Overfill Prevention

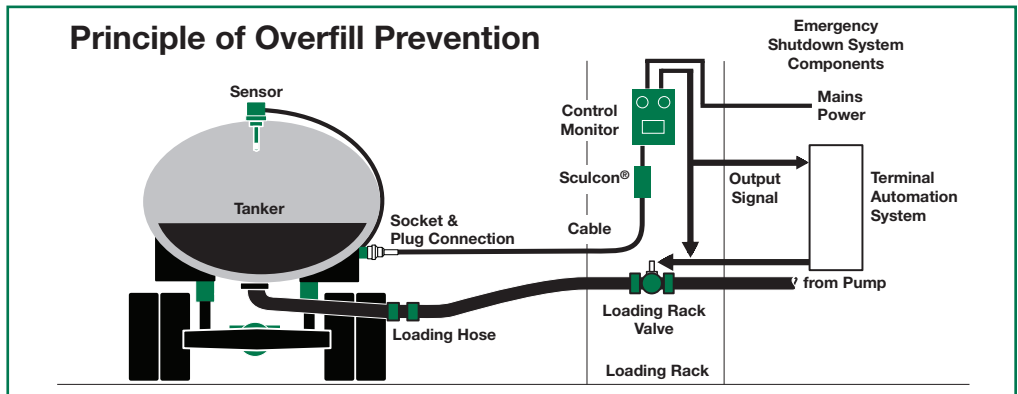

IEC 61508 SIL 3 Capable

$\lambda_{DU}=1.0 \text{ FIT}^*$   $\lambda_{SU}=116 \text{ FIT}^*$

\*FIT = Failure In Time ( $1 \times 10^{-9}$  failures per hour)

## FEATURES AND BENEFITS

- Maximum safety with Dynacheck – Automatic and continuous self-checking circuitry when used with Scully electronic rack and vehicle onboard monitoring systems.
- Scully's field-proven electro-optics technology.
- Wide Temperature Range.
- Adjustable Sensing Level.
- Instant-On™ – Instant permissive signal. No warmup time required.
- Quick purging of liquid – "fast" repermit as product level drops below the sensing point.
- Fully compatible with all Scully optic controllers.
- FM approvals for Class I, Division 1, Groups C and D hazardous locations in the US and Canada.
- Meets requirements of API Recommended Practice RP-1004.



60678 Rev E

**All Dimensions in Inches  
(Millimeters in Parenthesis)**

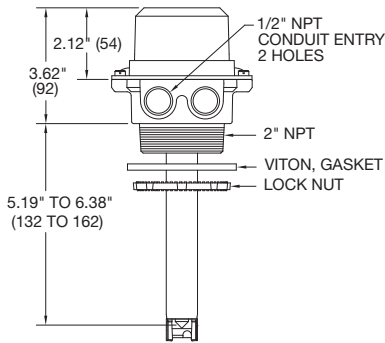

**SP-FU/MHC**

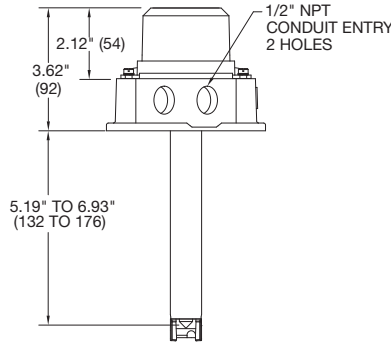

**SP-FU/MHCF**

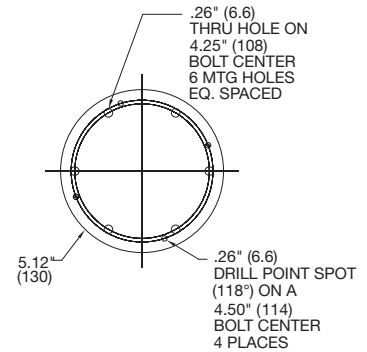

**Holder Mounting  
SP-FU/MHCF**

**TECHNICAL SPECIFICATIONS**

**Operating Temp. Range:** -40°F to +140°F (-40°C to +60°C)  
**Petroleum Product Range:** Gasoline blends & light fuel oils  
**Exposed Materials:** Aluminum, zinc, borosilicate (Pyrex®) glass, epoxy, conductive nylon and Viton® seals  
**Level Repeatability:** ±1/16" (±1 mm)  
**Electrical Leads:** 18" (45cm) long, 22 AWG (0.33 mm²)

**Cable Entry:** Two holes, 1/2" NPT threads  
**Detection Level and Size:** The detection level is adjustable, refer to sensor outline drawing above, shown for 7" shaft length  
**Approvals:** The sensor is intrinsically safe for mounting in Class I, Division 1, Groups C & D Hazardous location in accordance with Scully Control Unit approval ratings.

**SIL Capable**



**ORDERING INFORMATION**

Model	Description	Shaft Length	Part Number
SP-FU/MHC(MC)	Five-Wire Optic Sensor, 2" NPT holder, 2 1/8" Medium Cap	7" (175mm)	09208L1
		12" (300mm)	09213L1
		15" (375mm)	09216L1
SP-FU/MHCF(MC)	Five-Wire Optic Sensor, flanged holder, 2 1/8" Medium Cap	7" (175mm)	09207L1
		12" (300mm)	09212L1
		15" (375mm)	09215L1

**REPLACEMENT PARTS**

Model	Description	Shaft Length	Part Number
SP-FU	Five-Wire Optic Sensor, (without holder)	7" (175mm)	09209L1
		12" (300mm)	09214L1
		15" (375mm)	09217L1
SP-MHC(MC)	2" NPT Threaded Holder Only		09065
SP-MHCF(MC)	Flanged Holder Only		08265

Copyright © 2014 Scully Signal Company. Dynacheck, Dynamic Self-Checking, Dynamic Self-Testing, Faylsafe, IntelliCheck, Intellitrol are registered trademarks of Scully Signal Company. All Rights Reserved. Specifications are subject to change without notice.

Viton® is a registered trademark of DuPont. Pyrex® is a registered trademark of Corning.

60678 Rev E  
June 2016



**Scully Signal Company**  
 70 Industrial Way  
 Wilmington, MA 01887, USA  
 800 272 8559 • sales@scully.com

**Scully Systems Europe NV**  
 Maanstraat 25  
 2800 Mechelen, Belgium  
 +32 (0) 15 56 00 70 • info@scully.be

**Scully UK Ltd**  
 Meridian House, Unit 33  
 37 Road One Winsford Industrial Estate,  
 Winsford Cheshire CW7 3QG, UK  
 +44 (0) 1606 553805 • sales@scullyuk.com

