

# SmartLine STIW400 Wireless Temperature DI Transmitter Specification

34-SW-03-11, April 2022



## Model STIW400

- Up to 4 channels of inputs for T/C's or mV.
- Up to 2 channels of RTD's or 3-wire resistance.
- Up to 4 channels for discrete input or 2-wire resistance.

## Introduction

SmartLine Wireless Temperature continues the evolution of Honeywell's wireless transmitter product offering and provides the latest critical advancements to support industrial automation users' desire to expand wireless use for monitoring and control.

With over 14 years of industrial wireless experience, the SmartLine Wireless Temperature builds upon and is compatible with the current XYR 6000 product portfolio. Similar to the XYR 6000 wireless transmitter, the SmartLine Wireless product line is part of the Honeywell OneWireless™ system and is ISA100 - ready.

The SmartLine Wireless Temperature transmitter enables customers to obtain data and create information from remote and hazardous measurement locations without the need to run wires, where running wire is cost prohibitive and/or the measurement is in a hazardous location. Without wires, transmitters can be installed and operational in minutes, quickly providing information back to your system.

The previous generation transmitters primarily were applied to monitoring applications but experienced users know that Honeywell's wireless products are as reliable, secure, and safe as their wired counterparts. With this knowledge, users are now looking for wireless transmitters for use in specific control applications.



**Figure 1 — SmartLine Wireless Temperature DI Transmitter**

SmartLine Wireless introduces a step change in performance and most notably, performance suitable for control. SmartLine Wireless performance is improved in these ways:

- Fast ½ second publication rate.
- Higher radio range coverage.
- More powerful 4dBi integral antenna.
- Smarter local display with more local diagnostics and radio signal and quality indicators.
- More input channels and types than earlier.

SmartLine Wireless Temperature retains the following desirable features from the XYR 6000 product offering:

- Mesh or non-mesh configuration within each transmitter.
- Generic, off-the-shelf lithium ion battery.
- Two “D” size batteries for longer life.
- Choice of over-the-air or local provisioning (network security join key).
- Over-the-air firmware upgrade capability.
- Unique, encrypted provisioning key delivered from the factory.
- Remote and integral antenna options.
- 24 VDC power option.
- Publication rates of 1, 5, 10, or 30 seconds, plus new selections of ½ seconds and 1, 15, 30, 60 minutes.
- Transmitter range (integral antenna) of 1150' (350 m) under ideal conditions.

The STIW400 is a high-performance Temperature transmitter featuring performance over a wide of temperature configurations and applications.

The SmartLine family is also fully tested and compliant with Experion® PKS providing the highest level of compatibility assurance and integration capabilities. SmartLine easily meets the most demanding application needs for Temperature measurement applications.

## SmartLine Wireless Features

**Local and over-the-air provisioning capability:** All Honeywell wireless devices feature a secure method to join the local wireless network, also known as provisioning. SmartLine Wireless transmitters feature two methods to provision a transmitter onto the network which are either by using a handheld device to locally communicate through the IR interface or remotely using the over-the-air function. The over-the-air function is managed by the OneWireless gateway, Wireless Device Manager (WDM).

**Over-the-air firmware updates:** Once joined as a member of your OneWireless network, the WDM can download new transmitter firmware releases to each SmartLine Wireless transmitter over the wireless network. Locating and accessing the transmitter locally is not required thus saving time and keeping your personnel in safe environments.

**Mesh and non-mesh capability:** All SmartLine Wireless transmitters can be configured to operate in either a mesh network or a star (non-mesh) network. The configuration is specific to each wireless transmitter and thus the network can consist of a mixture of meshing and non-meshing devices. Non-meshing is desirable for deterministic communications which is preferred for control.

**Transmission power setting:** To comply with local and regional requirements, SmartLine Wireless transmitters are set at the factory to the maximum transmission power setting allowed for the country of use.

**Non-proprietary battery:** Sourcing lithium thionyl chloride batteries is much simpler since SmartLine Wireless utilizes commercial off-the-shelf batteries. Please see the list of approved battery manufacturers later in this specification. Batteries are housed in an IS-approved battery compartment making battery changes safe and easy.

**Backward compatibility:** SmartLine Wireless transmitters can join existing OneWireless networks and interoperate with existing XYR 6000 wireless transmitters or other ISA100 Wireless compliant transmitters or networks.

## OneWireless Network Features

The core of the Honeywell wireless solution is the OneWireless Network which consists a gateway, access point(s), and field routers.

The Wireless Device Manager (WDM) serves as the gateway function and in this role, manages the communication from the wireless field devices to the process control application. Typically, the WDM connects logically to the process control network (Level 2 or wireless DMZ). As the wireless network manager, the WDM provides easy access to the entire wireless network through a browser-based user interface. The Honeywell WDM can manage devices communicating over the ISA100 Wireless protocol and the Wireless HART™ protocol.

The ability to deploy redundant WDMs improves the reliability ensuring no loss of process data which is a requirement for control applications.

The Field Device Access Point (FDAP) serves in two roles in the OneWireless network infrastructure, which are: 1) access point, and 2) field router. As an access point, the FDAP directly connects to the WDM via Ethernet LAN cable. More than one access point is permitted and, when more than one is present, it ensures dual path for communications into the WDM from the field devices. As a field router, the FDAP located in the field would communicate to the FDAP acting as an access point. Using the FDAP as a router is more efficient than using field devices as routers since FDAPs are line powered devices whereas field devices are typically battery powered, and the FDAP offers greater range. The meshing capability of FDAPs allows flexibility in the setup of the wireless network to fit the requirements for wireless network performance, in terms of reliable communications, performance, and future growth. The choice of non-meshing network may be desirable for reduced communication latencies with a FDAP serving as a field router.

## Wireless Specifications

Table 1

Parameter	Description
<b>Wireless Communication</b>	2,400 to 2,483.5 MHz (2.4 GHz) Industrial, Scientific and Medical (ISM) band. DSSS – Direct Sequential Spread Spectrum per FCC 15.247 / IEEE 802.15.4 2006. Every data packet transmitted in either direction is verified (CRC check) and acknowledged by the receiving device. USA – FCC Certified. Canada – IC Certified. European Union – Radio Equipment Directive compliant.
<b>DSSS RF Transmitter Power</b>	NA Selection –100 mW (20.0 dBm) maximum EIRP including antenna for USA and Canadian locations. EU Selection – 63 mW (18.0 dBm) maximum EIRP including antenna per RTTE/ETSI for EU locations. Compliant to ETSI EN 300 328 wireless standard.
<b>Data</b>	PV Publish Cycle Time: Configurable as 1, 5, 10, 30 seconds, plus 1, 15, 30, 60 minutes Rate: 250 Kbps.
<b>Antennas</b>	Integral – 4 dBi omnidirectional monopole (default selection). Remote – 8 dBi omnidirectional monopole with up to two 10 m cables and lightning surge arrester. Remote – 14 dBi directional parabolic with up to two 10 m cables and lightning surge arrester.
<b>Signal Range</b>	Nominal 350 m (1150 feet) between Field Transmitter and Infrastructure Unit (FDAP) when using 4 dBi Integral antenna with a clear line of sight*.

\*Actual range will vary depending on antennas, cables and site topography.

## Specifications

### Operating Conditions

Table 2

Parameter	Reference Condition (at zero static)		Rated Condition		Operative Limits		Transportation and Storage	
	°C	°F	°C	°F	°C	°F	°C	°F
<b>Ambient Temperature<sup>1</sup></b>	25 ±1	77 ±2	-40 to 85	-40 to 185	-40 to 85	-40 to 185	-40 to 85	-40 to 185
<b>Ambient Temperature LCD Display visible range</b>	25 ±1	77 ±2	-20 to 70					
<b>Humidity %RH</b>	10 to 55		0 to 100		0 to 100		0 to 100	
<b>Vibration</b>	Maximum of 4g over 15 to 200Hz.							
<b>Shock</b>	Maximum of 40g.							
<b>Power</b>	Commercially available, non-proprietary 3.6V Lithium thionyl chloride (LiSOCl <sub>2</sub> ) batteries, non-rechargeable, size D. Battery pack-only option is available. Approved list of the manufacturer models: <ol style="list-style-type: none"> <li>1. Xeno Energy XL-205F</li> <li>2. Eagle Picher PT-2300H</li> <li>3. Tadiran TL-5930/s</li> </ol>							
	24 VDC power option. For Non I.S. application: 16 to 28 VDC input range, max input current 100mA. For I.S. application: Barrier in accordance with the control drawing required, entity parameters 30V, 120mA, 0.9W.							

<sup>1</sup> The Ambient Limits shown are for Ordinary Non-Hazardous locations only. Refer to the Hazardous Locations Approvals section for the Ambient Limits when installed in Hazardous Locations.

**Remote Antenna Cables**

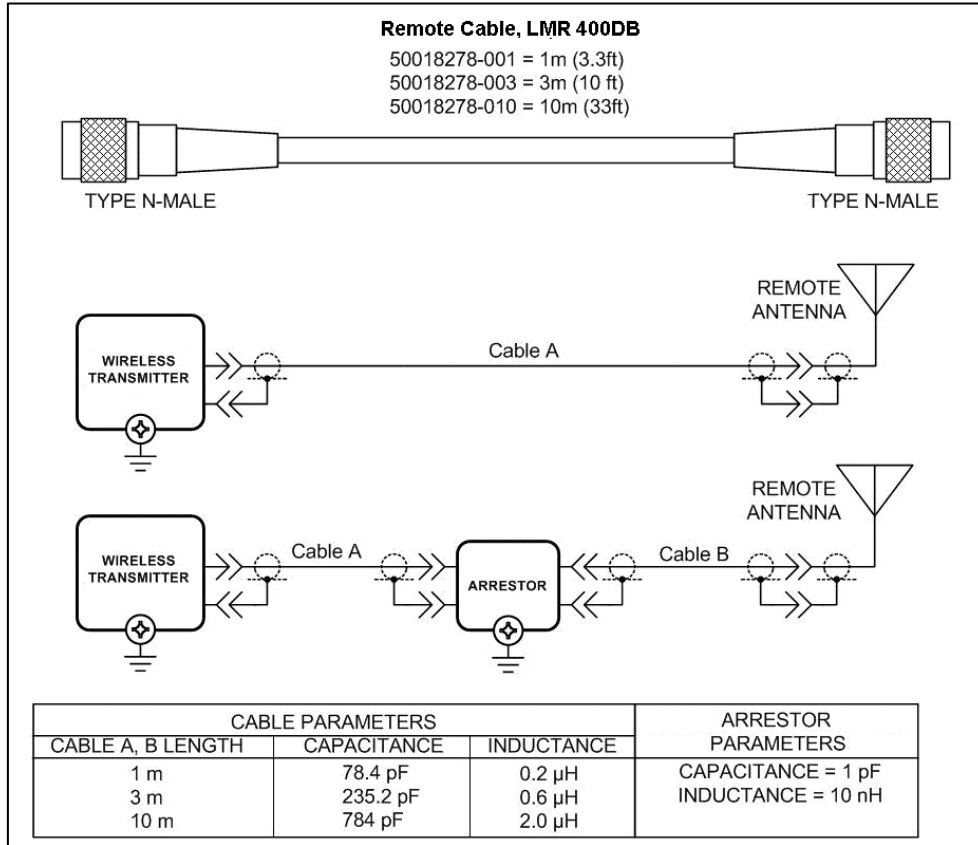

**Remote Antennas**

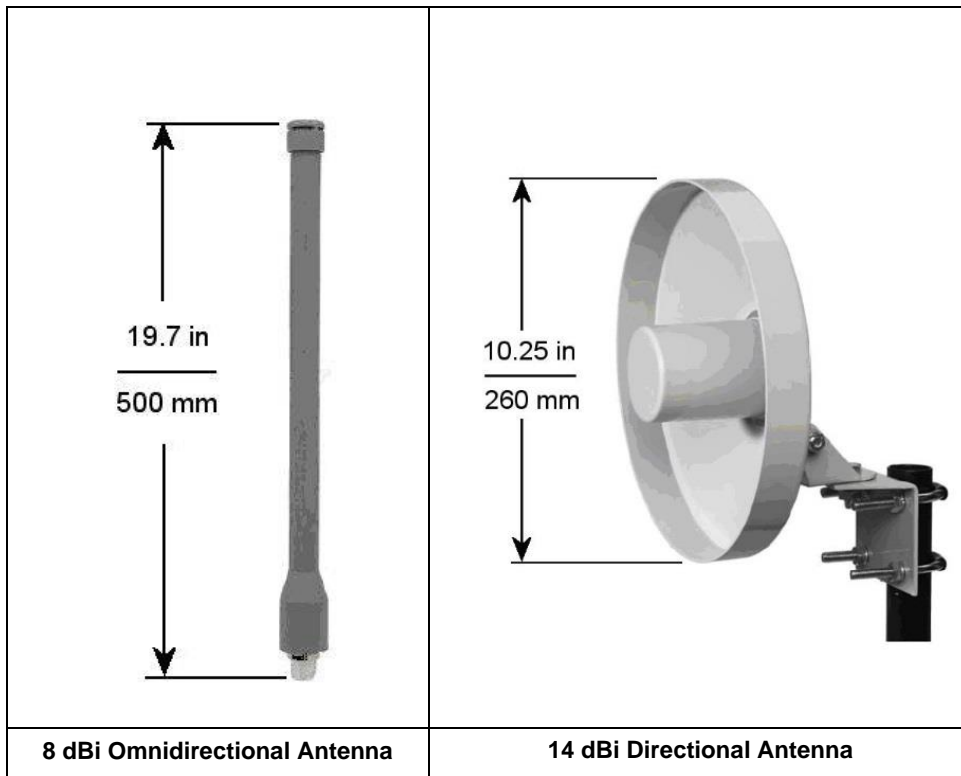

## Performance Specifications

### Performance under Rated Conditions\*

Table 3

Parameter	Description
<b>Accuracy *</b>	±0.10% of range at reference conditions for T/C's and mV. ±0.20% of range at reference conditions for RTD and 2/3-Wire resistance measurement, and for DI threshold setting.
<b>Temperature Effects</b>	±0.01% of full scale per °C.
<b>Stability</b>	±0.10% of URL per year.
<b>Stray Rejection</b>	Common Mode (50 or 60 Hz): 120 dB Normal Mode (50 or 60 Hz): 40 dB
<b>Maximum Lead Wire Resistance</b>	50 ohms/leg for all analog input types.
<b>Discrete Input</b>	Single SPST dry contacts. Maximum "ON" contact resistance of 200 Ohms *** Minimum "OFF" contact resistance of 300 Ohms *** Resistances must include all field wiring.
<b>Cold Junction Accuracy</b>	±0.5 °C
<b>Lightning Surge Arrester (Remote antenna only)</b>	Frequency range: 0 – 3 GHz, 50 Ohms, VSWR = 1:1.3 Max, Insertion Loss = 0.4 dB Connectors Type N Female, Max, Gas Tube Element: 90 V ± 20%, Impulse Breakdown Voltage = 1,000 V ± 20%, Maximum Withstand Current = 5 KA.
<b>Hazardous Location Certifications</b>	See the Model Selection Guide on page <a href="#">17</a> .
<b>Electromagnetic Compatibility</b>	IEC 61326-1
<b>Lightning Surge Arrester (Remote antenna only)</b>	Frequency range: 0 – 3 GHz, 50 Ohms, VSWR = 1:1.3 Max, Insertion Loss = 0.4 dB Connectors Type N Female, Max, Gas Tube Element: 90 V ± 20%, Impulse Breakdown Voltage = 1,000 V ± 20%, Maximum Withstand Current = 5 KA.
<b>CE Conformity</b>	These transmitters are in conformity with the Radio Equipment Directive, ETSI EN 300 328 V2.1.1 including EMC standard EN61326-1 2013.

\* Field Calibration available for increased accuracy applications.

\*\* Performance specifications are based on reference conditions of 25°C (77°F), 10 to 55% RH.

\*\*\* Default values; user configurable.

## Physical Specifications

**Table 4**

<b>Parameter</b>	<b>Description</b>
<b>Mounting Bracket</b>	Carbon Steel (zinc-plated) or Stainless Steel angle bracket or flat bracket available.
<b>Electronic Housing</b>	Epoxy-Polyester hybrid paint. Low Copper-Aluminum with 1/2" NPT or M20 conduit connections. Meets NEMA 4X (hose down and corrosion resistant), IP 66/67 (hose down and submersible to 1m).
<b>Stainless Steel Housing (option)</b>	316 SS or Grade CF8M, the casting equivalent of 316 SS with M20 or 1/2" NPT conduit connections. If ordered with the Remote Antenna options, the antenna parts are not SS or Marine type cables; the integral antenna uses SS parts.
<b>Mounting</b>	Can be mounted in virtually any position using the standard mounting bracket. Mounting should result in the antenna being vertically oriented. Bracket is designed to mount on 2-inch (50 mm) vertical or horizontal pipe. See Figure 2 and 3.
<b>Dimensions</b>	See Figure 4, Figure 5 and Figure 6.
<b>Net Weight</b>	Approximately 9 pounds (4.1 Kg) <sup>1</sup>

<sup>1</sup> Add 8.0 pounds (3.6 Kg) to any model equipped with the stainless steel housing option (Model Selection Guide Table IV selection M or N).

## STIW400 ISA100.11a Compliant Inputs

Any combination of sensor type inputs is allowed. The input channels can be configured for the following input types by using the OneWireless User Interface with the corresponding device descriptor file:

**Table 5**

Channel 1	Channel 2	Channel 3	Channel 4
RTD, 3W Resistance	Not a valid configuration	RTD, 3W Resistance	Not a valid configuration
RTD, 3W Resistance	Not a valid configuration	T/C, mV, DI, 2W Resistance	T/C, mV, DI, 2W Resistance
T/C, mV, DI, 2W Resistance	T/C, mV, DI, 2W Resistance	RTD, 3W Resistance	Not a valid configuration
T/C, mV, DI, 2W Resistance	T/C, mV, DI, 2W Resistance	T/C, mV, DI, 2W Resistance	T/C, mV, DI, 2W Resistance

Selecting any RTD / 3-Wire Ohm Resistance input on Channel 1 and on Channel 3 renders Channel 2's and Channel 4's input terminals unavailable.

The transmitter measures the analog signal from temperature sensors, discrete inputs, millivolt values or ohm values and transmits a digital output signal proportional to the measured value for direct digital communications with systems.

The discrete input channels support voltage-free floating contacts. Maximum ON contact resistance is 200 ohms. Minimum OFF contact resistance is 300 ohms. Discrete Input threshold values are user configurable.

The Process Variable (PV) is available for monitoring and alarm purposes. The cold junction temperature is also available for monitoring. Available PV update rates are 1, 5, 10, or 30 seconds, plus new selections of ½ sec (Refer User Manual for applicable conditions) and 1, 15, 30, 60 minutes and are set using the Wireless Builder. Slower update rates extend battery life.



## Input Types and Ranges

**Table 6**

<b>Input Type</b>	<b>Range Deg. F</b>	<b>Range Deg. C</b>
Pt100 RTD (alpha 0.00385)	-300 to +1200	-184 to +649
Pt200 RTD	-300 to +1200	-184 to +649
Pt500 RTD	-300 to +1200	-184 to +649
Type B T/C	0 to 3300	-18 to +1816
Type E T/C	-454 to +1832	-270 to +1000
Type J T/C	0 to 1600	-18 to + 871
Type K T/C	0 to 2400	-18 to +1816
Type N T/C	0 to 2372	-18 to +1300
Type R T/C	0 to 3100	-18 to +1704
Type S T/C	0 to 3100	-18 to +1704
Type T T/C	-300 to +700	-184 to +371
Millivolts	0 to 10 mV 0 to 50 mV 0 to 100 mV	
2W and 3W Resistance (Ohms)	0 to 100Ω 0 to 200Ω 0 to 500Ω 0 to 1000Ω	
Discrete input	200 Ohms Max ON Contact Resistance (user configurable) 300 Ohms Min OFF Contact Resistance (user configurable)	

## STIW400 TEMPERATURE TRANSMITTER CONNECTIONS

T/C or mV or DI or 2 Wire Resistance

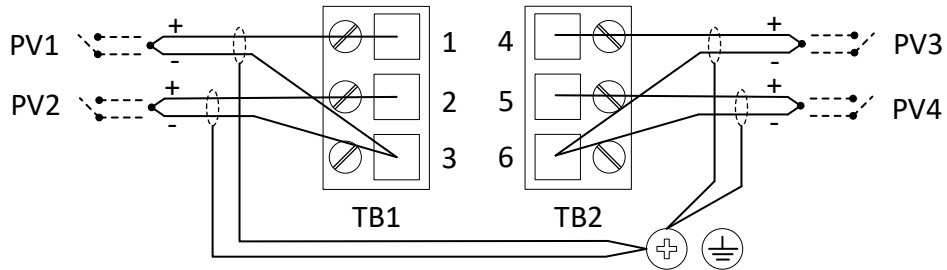

3 Wire RTD or Resistance

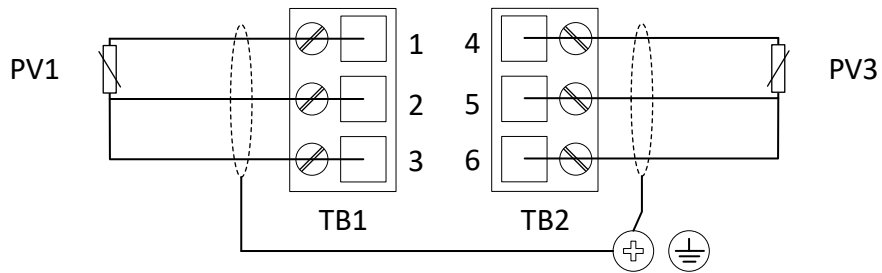

3 Wire RTD or Resistance

T/C or mV or DI or 2 Wire Resistance

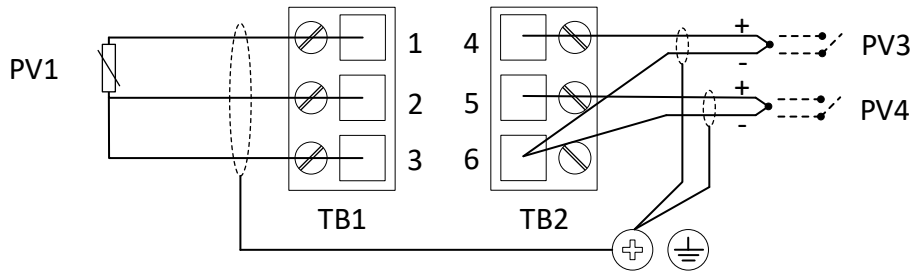

**Mounting and Dimensions**

Reference Dimensions:

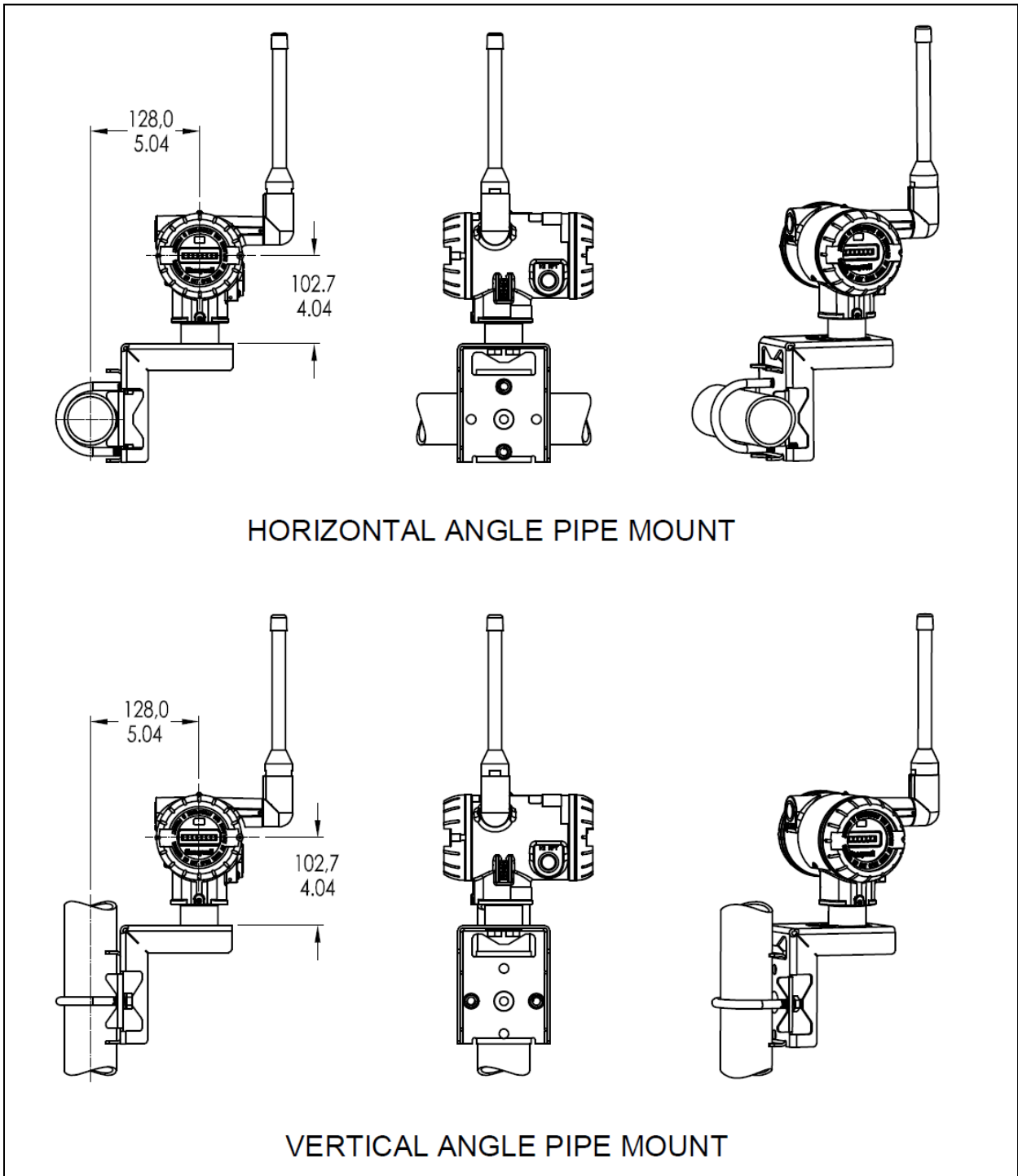

Figure 2 — Examples of typical mounting positions

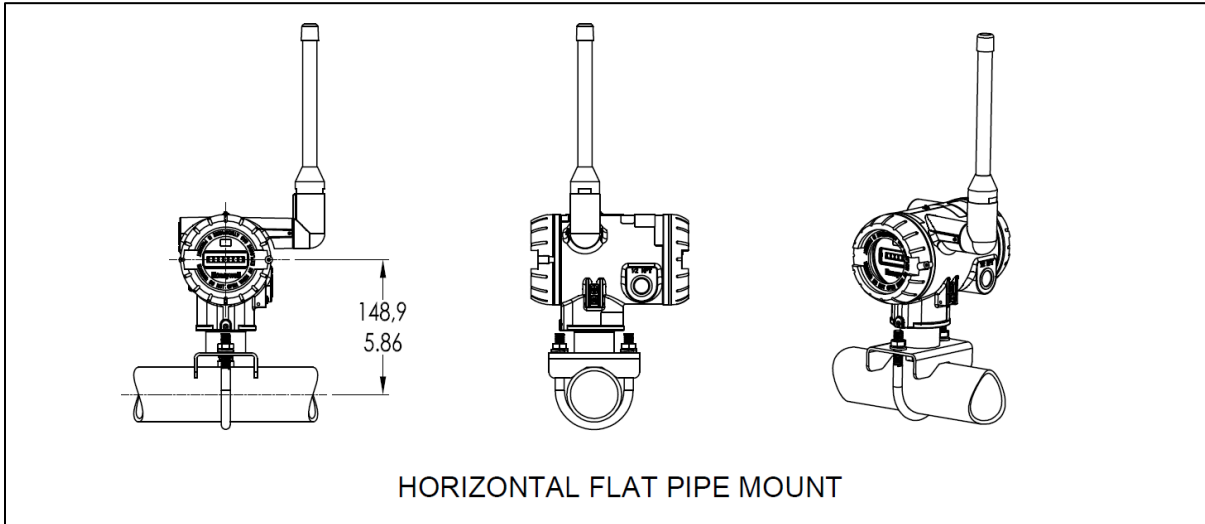

Figure 3 — Examples of typical mounting positions

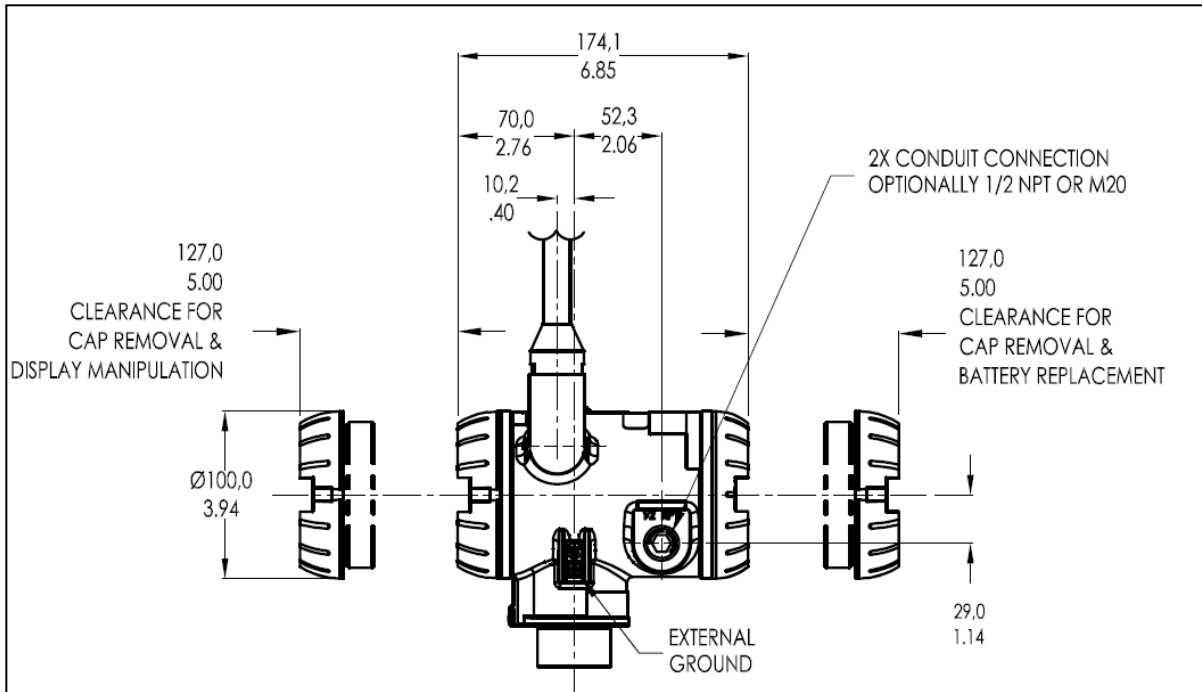

Figure 4 — STIW400 Informational and dimensional drawing

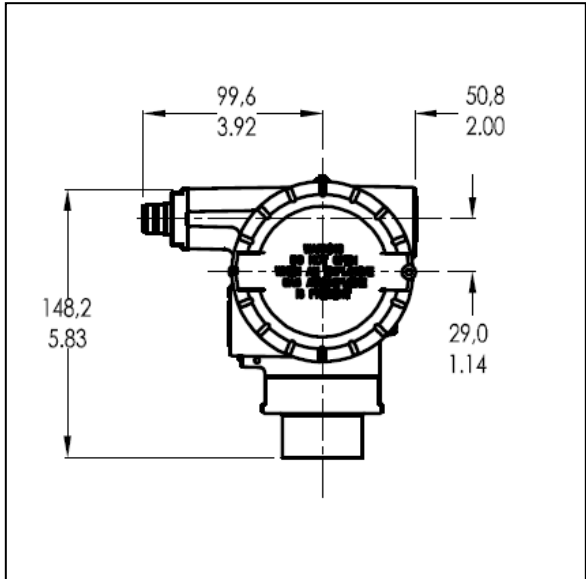

Figure 5 — Typical mounting dimensions for STIW400

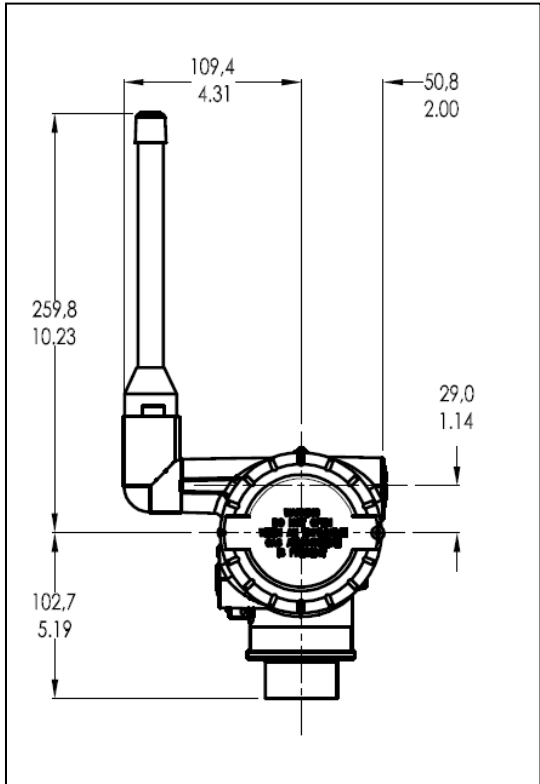

Figure 6 — Typical mounting dimensions for STIW400

### Hazardous Locations Approvals

Refer to control drawing 50136129, in the user manual #34-SW-25-04, for intrinsically safe installation details.

**Table 7**

AGENCY	TYPE OF PROTECTION	Ambient Temperature	
<b>CSA</b>  <b>(USA and Canada)</b>	<b>Intrinsically Safe:</b> Class I; Division 1; Groups A, B, C, D; Class II, Division 1, Groups E, F, G; Class III, Division 1; T4 Class I, Zone 0 AEx ia IIC T4 Ga Class I Zone 2 AEx ic IIC T4 Gc Ex ia IIC T4 Ga Ex ic IIC T4 Gc	-40 to +80°C: ia -40 to +85°C: ic	
	<b>Non Incendive:</b> Class I; Division 2; Groups A, B, C, D; Class II, Division 2, Groups E, F, G; Class III, Division 2, T6...T4 Ex nA [ia Ga] IIC T6...T4 Gc Class I, Zn 2, AEx nA [ia Ga] IIC T6...T4 Gc	-40°C to +85°C : T5 -40°C to +75°C : T6	
	<b>Explosion-Proof/ Flameproof/Dust Proof:</b> Class I, Division 1; Groups A, B, C, D; Class II, Division 1, Groups E, F, G; Class III, Division 1; T6...T4 Ex db [ia Ga] IIC T6...T4 Gb Ex tb [ia Da] IIIC T95...T125 Db Class I, Zn 1 AEx db [ia Ga] IIC T6...T4 Gb Class II, Zn 21, AEx tb [ia Da] IIIC T95...T125 Db	-40°C to +85°C : T5 -40°C to +75°C : T6  -40°C to +85°C : T95	
	<b>Enclosure:</b> Type 4X/ IP66/ IP67		
	<b>Standards Used:</b> CSA C22.2 No. 0-10 CSA C22.2 No.94.2-15 CSA C22.2 No.213-16 CAN/CSA C22.2 No.60079-1:16 CAN/CSA C22.2 No.60079-31:15 ANSI/UL 60079-1-2015 ANSI/UL 60079-31-2015 FM 3616 – Dec 2011 ANSI/UL 50E-2015	CSA C22.2 No.25-17 CAN/CSA C22.2 No.61010-1-12 CAN/CSA C22.2 No.60529:16 CAN/CSA C22.2 No.60079-11:14 ANSI/ISA 12.12.01-2015 ANSI/UL 60079-11-2014 FM 3600 – Dec 2011 ANSI/IEC 60529 – 2004 ANSI/UL 61010-1-2016	CSA C22.2 No.30-M1986 CAN/CSA C22.2 No.157-92 CAN/CSA C22.2 No.60079-0:15 CAN/CSA C22.2 No.60079-15:16 ANSI/UL 60079-0-2013 ANSI/UL 60079-15-2013 FM 3615 – Aug 2006 ANSI/UL 913-2015
<b>FM Approvals TM (USA)</b>	<b>Intrinsically Safe:</b> IS Class I, II, III; Division 1; Groups ABCDEFG; T4 Class I, Zone 0 AEx ia IIC Ga T4 Class I, Zone 2[0] AEx ic [ia Ga] IIC Gc T4	-40 °C to +85 °C	
	<b>Non Incendive:</b> NI-AIS Class I; DIV 2; Groups ABCD; T5...T6 Class I, Zone 2[0] AEx nA [ia Ga] IIC Gc; T5...T6	-40 °C to +85 °C : T5 -40 °C to +70 °C : T6	
	<b>Dust Proof:</b> DIP-AIS Class II, III DIV 1; Groups EFG; T5...T6 Zone 21[20] AEx tb [ia Da] IIIC T95°C Db	-40 °C to +85 °C : T5, T95 -40 °C to +70 °C : T6	
	<b>Enclosure:</b> Type 4X/ IP66/ IP67		
	<b>Standards Used:</b> FM 3600:2018 ANSI/ISA 60079-0: 2013 ANSI/ ISA 60079-15: 2013 ANSI/ NEMA 250: 2008	FM 3610: 2018 FM 3810: 2018 ANSI/ ISA 60079-31: 2015	FM 3611: 2018 FM 3616: 2011 ANSI/ ISA 60079-11: 2014 ANSI/ ISA 60529: 2004

AGENCY	TYPE OF PROTECTION	Ambient Temperature Product Applicability	
<b>ATEX</b>	<b>Intrinsically Safe:</b> II 1 G Ex ia IIC T4 Ga II 3 G Ex ic IIC T4 Gc	-40 to +80°C: ia -40 to +85°C: ic	
	<b>Flameproof / Dust Proof:</b> II 2[1] G Ex db [ia Ga] IIC T6...T4 Gb II 2[1] D Ex tb [ia Da] IIIC T95C...T125C Db	-40°C to +85°C : T5 -40°C to +75°C : T6	
	<b>Non Incendive:</b> II 3[1] G Ex ec [ia Ga] IIC T6...T4 Gc	-40°C to +85°C : T5 -40°C to +75°C : T6	
	<b>Enclosure:</b> IP66/ IP67		
	<b>Standards Used:</b> EN 60079-0 : 2012 + A11:2013	EN 60079-1 : 2014 EN 60079-7 : 2015	EN 60079-11 : 2012 EN 60079-31 : 2014
<b>IECEx</b>	<b>Intrinsically Safe:</b> Ex ia IIC T4 Ga Ex ic IIC T4 Gc	-40 to +80°C: ia -40 to +85°C: ic	
	<b>Flameproof / Dust Proof:</b> Ex db [ia Ga] IIC T6...T4 Gb Ex tb [ia Da] IIIC T95C...T125C Db	-40°C to +85°C : T5 -40°C to +75°C : T6	
	<b>Non Incendive:</b> Ex ec [ia Ga] IIC T6..T4 Gc	-40°C to +85°C : T5 -40°C to +75°C : T6	
	<b>Enclosure:</b> IP66 /IP67		
	<b>Standards Used:</b> IEC 60079-0 : 2017	IEC 60079-1 : 2014 IEC 60079-7 : 2015	IEC 60079-11 : 2011 IEC 60079-31 : 2013

---

## **Transmitter Options**

(indicated selection code is shown)

### ***ISA100 Wireless Release Selections (A or B)***

OneWireless R2xx represents the previous releases whereas R3xx is the current release. A OneWireless system with R3xx firmware can host R2xx and R3xx devices. Please select the option to match the targeted OneWireless system.

### ***Remote Antenna and Cables (M or D)***

The user can select one of the optional remote antennas listed. The selection of the antenna option automatically includes the remote antenna adapter.

To complete the option selection, one of the remote antenna cables (1, 2, or 3) must also be selected.

### ***Lightning (Surge) Diverter and Cables (1, 2, or 3)***

The lightning surge diverter options includes the surge diverter and cable. The diverter features Type N connections (female) on both ends. The remote antenna adapter is not included.

### ***Remote Antenna Adapter (A)***

This option provides an adapter to be inserted into the opening where the integral antenna normally connects. The adapter is designed to connect to a remote antenna that the user supplies. It features a female Type N connection.

### ***Destination Country (CA, EU, or US)***

This selection sets the transmission power at the factory to comply with the installation country location.

### ***Mounting Brackets (1, 3, 5, or 7)***

The angle mounting bracket is available in either zinc-plated carbon steel or 316 stainless steel and is suitable for horizontal or vertical mounting on a two-inch (50 millimeter) pipe, as well as wall mounting.

An additional flat mounting bracket is also available in carbon steel and 316 stainless steel for two-inch (50 millimeter) pipe mounting.

### ***Tagging (Option 1 or 2)***

The choice of 1 or 2 stainless steel wired-on tags is available. Each tag can accommodate additional data of up to 4 lines of 28 characters. The number of characters includes spaces.

Note that the standard nameplate on the meter body contains the serial number and body-related data.

---



**Model Selection Guide**

Model Selection Guides are subject to change and are inserted into the specifications as guidance only.



Section 13  
Page: STIW4-1  
Effective Date: March 11, 2022

**Model STIW400  
SmartLine Wireless Temperature and Discrete Input  
Transmitter**

**Model Selection Guide  
with Price Data**

Model Selection Guide:  
34-SW-16-40 Issue 5

Honeywell Proprietary

**Instructions:** Make selections from all Tables: Key through XIII using column below the proper arrow. Asterisk indicates availability. Letter (a) refer to restrictions highlighted in the restrictions table. Tables delimited with dashes.  
**List Price:** Price equals the sum of prices for all selections made.

Key	I	II	III	IV	V	VI	VII	VIII	IX
STIW	-	-	-	-	-	-	-	-	00000

KEY NUMBER	DESCRIPTION
Type	Wireless Temperature or Input – four inputs (1-4) T/C, mV, DI, ohm, or two (2) RTD

Selection	Availability
STIW400	↓

TABLE I	RESERVED MULTI-OPTION
No selection	

000000	*
--------	---

TABLE II	RESERVED OPTION
No Selection	

0	*
---	---

TABLE III	Agency Approvals (see data sheet for Approval Code Details)
Approvals	No Approvals Required ATEX and IECEx Explosion proof, Intrinsically Safe, Non-incendive & Dustproof CSA US Explosion proof, Intrinsically Safe, Non-incendive, & Dustproof FM Intrinsically Safe, Non-incendive and Dustproof

0	*
A	*
B	*
H	*

**TABLE IV HOUSING and ELECTRONICS SELECTIONS**

	Material	Connection	Paint Color
a. Electronic Housing Material & Connection Type	Epoxy Polyester Hybrid Coated Aluminum	1/2 NPT	Standard (Blue / Gray)
	Epoxy Polyester Hybrid Coated Aluminum	M20	Standard (Blue / Gray)
	316 Stainless Steel (Grade CF8M)	1/2 NPT	Standard (no paint)
	316 Stainless Steel (Grade CF8M)	M20	Standard (no paint)
b. Output Protocol	Wireless Protocol		
	ISA100 Wireless 2.0 compatible (equivalent OW R300 or newer) ISA100 Wireless 1.0 compatible (equivalent to OW R2xx)		
c. Power	Power Options		
	Battery Holder Only - No Battery Included Battery Power - Batteries included 24 VDC power		
	Antenna Options		
d. Antennas	Integral Right-angle, vertical 4 dBi		
	Remote Omnidirectional, 8 dBi		
	Remote Directional, 14 dBi		
	Remote Antenna Adapter only, Type N Connection		
e. Remote Antenna Cable	Remote Antenna Cable		
	None		
	Type N Remote Cable, 1.0 m (required for connection to transmitter)		
	Type N Remote Cable, 3.0 m (required for connection to transmitter) Type N Remote Cable, 10.0 m (required for connection to transmitter)		
f. Surge Diverter and Cable	Lightning Surge Diverter and Remote Cable		
	None		
	Surge Diverter and Type N Cable (1.0 m) Surge Diverter and Type N Cable (3.0 m) Surge Diverter and Type N Cable (10.0 m)		

C	*
D	*
M	*
N	*

_A_	*
_B_	*

_0_	*
_B_	*
_D_	*

_R_	*
_M_	*
_D_	*
_A_	*

_0_	*
_1_	*
_2_	*
_3_	*

_0_	*
_1_	*
_2_	*
_3_	*

TABLE V CONFIGURATION SELECTIONS	
a. Application Software	Diagnostics and Applications
	Standard Diagnostics
b. Country	Destination Country
	Canada
	European Union (RED compliant countries includes Australia)
	USA and Puerto Rico
c. General Configuration	Factory Standard

1	*
_ CA _	*
_ EU _	*
_ US _	*
___ S	*

TABLE VI CALIBRATION & ACCURACY SELECTIONS			
Accuracy and Calibration	Accuracy	Calibrated Range	Calibration Qty
	Standard	Factory Std	Single Calibration

A	*
---	---

TABLE VII ACCESSORY SELECTIONS		
a. Mounting Bracket	Bracket Type	Material
	None	None
	Angle Bracket	Carbon Steel
	Angle Bracket	316 SS
	Flat Bracket	Carbon Steel
b. Customer Tag	Customer Tag Type	
	No customer tag	
	One Wired Stainless Steel Tag (Up to 4 lines 26 char/line) Two Wired Stainless Steel Tag (Up to 4 lines 26 char/line)	
c. Unassembled Conduit Plugs & Adapters	Unassembled Conduit Plugs & Adapters	
	No Conduit Plugs or Adapters Required	
	1/2 NPT Male to 3/4 NPT Female 316 SS Certified Conduit Adapter	
	1/2 NPT 316 SS Certified Conduit Plug	
	M20 316 SS Certified Conduit Plug	
	Minifast® 4 pin (1/2 NPT) (not suitable for X-Proof applications) Minifast® 4 pin (M20) (not suitable for X-Proof applications)	

0	*
1	*
3	*
5	*
7	*
_ 0 _	*
_ 1 _	*
_ 2 _	*
__ A0	*
__ A2	n
__ A6	n
__ A7	m
__ A8	n
__ A9	m

TABLE VIII OTHER Certifications & Options: (String in sequence comma delimited (XX, XX, XX,....))	
Certifications & Warranty	None - No additional options
	Certificate of Conformance (F3391)
	Calibration Test Report & Certificate of Conformance (F3399)
	Certificate of Origin (F0195)
	Extended Warranty Additional 1 year
	Extended Warranty Additional 2 years
	Extended Warranty Additional 3 years
	Extended Warranty Additional 4 years

00	*	b
F3	*	
F1	*	b
F5	*	
01	*	
02	*	
03	*	
04	*	

TABLE IX Manufacturing Specials	
Factory	Factory Identification

00000	*
-------	---

MODEL RESTRICTIONS

Restriction Letter	Available Only with		Not Available with	
	Table	Selection(s)	Table	Selection(s)
m	IV a	D, N		
n	IV a	C, M		
b	Select only one option from this group			

**FIELD INSTALLABLE REPLACEMENT PARTS**

Description	Kit Number
1/2 NPT cocket plug (ZN plated CS)	50021832-501
1/2 NPT certified conduit plug (SS)	50021832-502
M20 conduit plug (ZN plated CS)	50000547-502
M20 certified conduit plug (SS)	50000547-501
Lightning surge diverter (order cable separately)	50018279-590
IS battery pack	50047517-501
24 VDC external power module	50136118-501
Integral right-angle, vertical 4 dBi, aluminum pure polyester	50030973-503
Integral right-angle, vertical 4 dBi, aluminum epoxy-polyester	50030973-504
Integral right-angle, vertical 4 dBi, stainless steel	50030973-505
Remote omnidirectional antenna, 8 dBi	50018414-501
Remote directional antenna, 14 dBi	50018415-501
Remote antenna adapter, Type N connection	50028364-501
Remote cable for antenna or accessories, Type N (1.0m)	50018278-501
Remote cable for antenna or accessories, Type N (3.0m)	50018278-503
Remote cable for antenna or accessories, Type N (10.0m)	50018278-510
Lithium thionyl chloride batteries (Qty 2)	50026010-501
Lithium thionyl chloride batteries (Qty 4)	50026010-502
Lithium thionyl chloride batteries (Qty 10)	50026010-503

Note P - For part number pricing please refer to Web Channel

**PRODUCT MANUALS**

Description	Part Number
SmartLine Wireless Temperature and UIO Transmitter User's Manual	34-SW-25-04

All product documentation is available at [www.honeywellprocess.com](http://www.honeywellprocess.com).

The minimum value of orders acceptable for Honeywell is USD 500. Handling fee is the amount of the difference between USD 500 and the actual purchase price.

## Sales and Service

For application assistance, current specifications, ordering, pricing, and name of the nearest Authorized Distributor, contact one of the offices below.

### ASIA PACIFIC

Honeywell Process Solutions,  
Phone: + 800 12026455 or  
+44 (0) 1202645583  
(TAC) [hfs-tac-support@honeywell.com](mailto:hfs-tac-support@honeywell.com)

#### Australia

Honeywell Limited  
Phone: +(61) 7-3846 1255  
FAX: +(61) 7-3840 6481  
Toll Free 1300-36-39-36  
Toll Free Fax:  
1300-36-04-70

#### China – PRC - Shanghai

Honeywell China Inc.  
Phone: (86-21) 5257-4568  
Fax: (86-21) 6237-2826

#### Singapore

Honeywell Pte Ltd.  
Phone: +(65) 6580 3278  
Fax: +(65) 6445-3033

#### South Korea

Honeywell Korea Co Ltd  
Phone: +(822) 799 6114  
Fax: +(822) 792 9015

### EMEA

Honeywell Process Solutions,  
Phone: + 800 12026455 or  
+44 (0) 1202645583

Email: (Sales)

[FP-Sales-Apps@Honeywell.com](mailto:FP-Sales-Apps@Honeywell.com)

or

(TAC)

[hfs-tac-support@honeywell.com](mailto:hfs-tac-support@honeywell.com)

### AMERICAS

Honeywell Process Solutions,  
Phone: (TAC) (800) 423-9883  
or (215) 641-3610  
(Sales) 1-800-343-0228

Email: (Sales)

[FP-Sales-Apps@Honeywell.com](mailto:FP-Sales-Apps@Honeywell.com)

or

(TAC)

[hfs-tac-support@honeywell.com](mailto:hfs-tac-support@honeywell.com)

### For more information

To learn more about SmartLine Transmitters,  
visit [www.process.honeywell.com](http://www.process.honeywell.com)  
Or contact your Honeywell Account Manager

### Process Solutions

Honeywell  
1250 W Sam Houston Pkwy S  
Houston, USA, TX 77042

Honeywell Control Systems Ltd  
Honeywell House, Skimped Hill Lane  
Bracknell, England, RG12 1EB

Shanghai City Centre, 100 Jungi Road  
Shanghai, China 20061

[www.process.honeywell.com](http://www.process.honeywell.com)

34-SW-03-11

April 2022

©2022 Honeywell International Inc.

The Honeywell logo is displayed in a bold, red, sans-serif font.