



**Lidec L20-70 DCPD - Polyester housing**  
**Application: cargo holds & dry compartments -**  
**water ingress**

The Lidec type L20-70 DCPD, is specially designed for water ingress detection and offers a dependable solution for detecting the presence of liquids within dry cargos. The Lidec L20-70 DCPD is based on the propagation of a surface wave. This design does not include any moving part.

The reliability of the device is ensured by a built-in function which monitors electronic or transducer failures.

The polyester housing is designed to be installed in areas protected against adverse weather conditions. The Lidec L20-70 DCPD does not require any calibration as it is not influenced by the surrounding cargo (e.g. coal, cement, or any powdery substance).

# L20-70 DCP - Technical Specifications

## Technical Data

<b>Accuracy:</b>	+/- 2 mm
<b>Operating temperature:</b>	-25°C to + 60°C
<b>Cargo temperature:</b>	up to + 70°C max.
<b>Intrinsically safe:</b>	II 1 G D Ex ia IIC or IIB T6, T5, T4 Ex ia IIIC T80°C or T95°C or T120°C Da IP6X LCIE 02 ATEX 6181X and IECEx LC11.0001X
<b>Power supply:</b>	18 to 28 Vdc (24 Vdc nominal)
<b>Protection class:</b>	IP66 for connecting box IP68 for sensor up to 100m depth
<b>Weight:</b>	0.9 kg

## Special Features

- Materials:
  - Probe: Stainless steel 316L
  - Connecting box : Polyester
- Horizontal or vertical mounting
- The L20-70 DCP operates even with cargos that may absorb water to form a paste
- Output signal:
  - 20 mA (outside liquid)
  - 7 mA (detection of liquid)
- Cable length: up to 30m max.
- Fully static device
- Fail-safe operation
- Insensitive to vibrations, shocks, electrical disturbances and solid cargo product
- Approved by major classification societies

## Technical Documentation

<b>Technical manual:</b>	NT406
<b>Maintenance manual:</b>	NT406

## Dimensions & Fixation

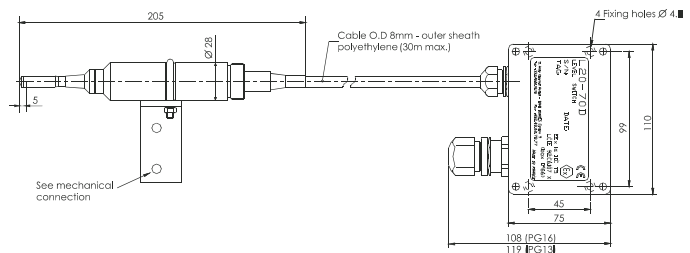

**Note:** Cable length needs to be specified 8 weeks before delivery

## Mechanical Connection

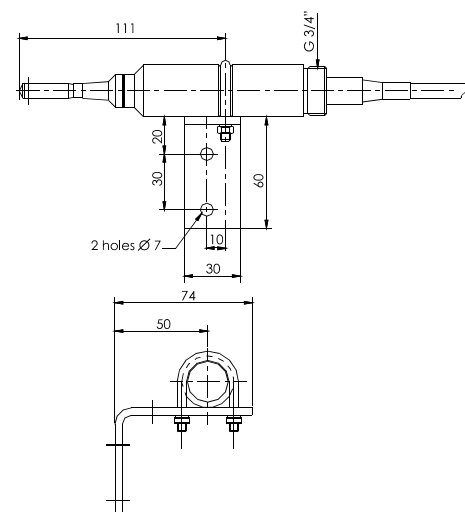

## Electrical Connection

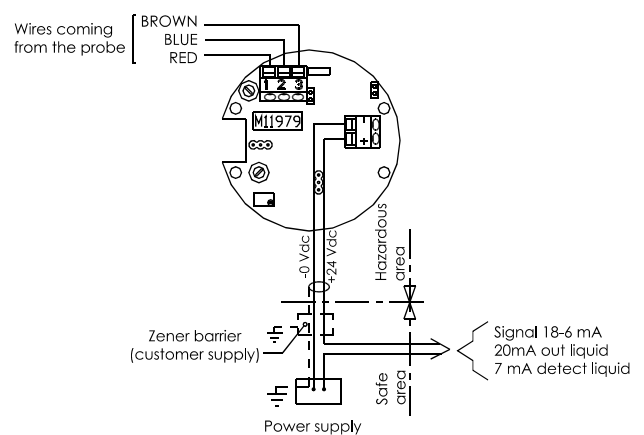

## Honeywell Marine SAS

9, rue Isaac Newton  
ZA Port Sec Nord, Esprit 1  
18000 Bourges – France  
Phone : + 33 (0) 248 237 901  
Fax : + 33 (0) 248 237 903  
E-Mail: [contact.marine@honeywell.com](mailto:contact.marine@honeywell.com)  
[www.honeywellmarine.com](http://www.honeywellmarine.com)

HM-11-47-ENG  
October 2013  
© 2013 Honeywell International Inc.

**Honeywell**